

# INSTALLATION AND MAINTENANCE MANUAL XN CHAIN HOIST

**XN16 - XN20 – XN25**

English

STD-K-KHA-F-CQD-ENG

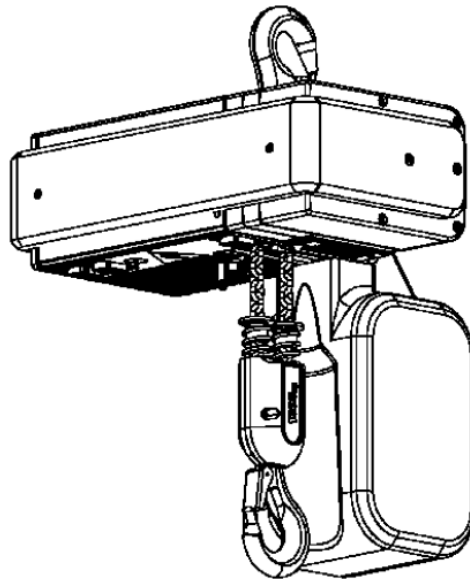

**THIS PAGE INTENTIONALLY LEFT BLANK**

**!!! CAUTION:** Read the instructions supplied with the product before installation and commissioning.

**!!! CAUTION:** Keep the instructions in a safe place for future reference.

**Table of contents**

<b>1</b>	<b>INTRODUCTION .....</b>	<b>5</b>
1.1	Contact Information .....	5
1.2	Warranty .....	5
1.3	Disclaimer .....	5
1.4	Safety .....	6
1.5	Placards and Instructions .....	8
<b>2</b>	<b>INSTALLATION .....</b>	<b>9</b>
2.1	General .....	9
2.2	Chain Container Installation .....	9
2.3	Lubrication .....	9
2.4	Mounting .....	10
2.5	Load Hook Throat Opening .....	10
2.6	Electrical Connection .....	11
2.7	Three Phase Power Connections .....	12
<b>3</b>	<b>INITIAL START-UP .....</b>	<b>13</b>
3.1	General .....	13
3.2	Correcting the Direction of Hook Travel .....	13
3.3	Operational Checks – No Load .....	14
3.4	Operational Checks – With Load .....	14
<b>4</b>	<b>HOIST OPERATION .....</b>	<b>15</b>
<b>5</b>	<b>MAINTENANCE .....</b>	<b>17</b>
5.1	Basic Hoist Construction .....	17
5.2	Hoist Motor and Brake Assembly .....	18
5.2.1	Replacement Criteria for Motor Brakes .....	21
5.3	Torque Limiter (Refer to <i>Figure 5.4</i> ) .....	23
5.4	Load Chain .....	24
5.5	Maintenance Inspection .....	24
5.6	Load Chain Specifications (see <i>Figure 5.5</i> ) .....	26
5.7	Removing the Load Chain .....	26
5.8	Installing the Load Chain .....	27
5.9	Fall Stop Assembly (Refer to <i>Figure 5.8</i> ) .....	29
5.10	Chain Container .....	30
5.11	Upper and Lower Travel Safety Limit Switch .....	31
5.12	Upper and Lower Rotary Travel Limit Switch .....	32
5.13	Hooks .....	33
5.14	Hook Inspection .....	34
5.15	Hook Dimensions .....	35
5.16	Top Hook .....	36
5.17	Controls .....	37
5.18	Two Speed – Three Phase – 208 / 230 / 460 Volt – Power Circuit .....	39
5.19	Two Speed – Three Phase – 208 / 230 / 460 Volt – Control Circuit .....	40
5.20	Two Speed – Three Phase – 575 Volt – Power Circuit .....	41
5.21	Two Speed – Three Phase – 575 Volt – Control Circuit .....	42
5.22	Wiring Diagram – 3 Button – Push Button .....	43
5.23	Wiring Diagram – 5 Button – Push Button .....	44
5.24	Wiring Diagram – 7 Button – Push Button .....	45
<b>6</b>	<b>PREVENTATIVE MAINTENANCE .....</b>	<b>46</b>
6.1	Maintenance and Inspection Table .....	46

---

6.2	Lubrication .....	47
6.3	Recommended Technical Support for Various Spare Parts .....	48
6.4	Screw Tightening Torque (lb-ft) Specifications.....	48
6.5	Troubleshooting .....	49
<b>7</b>	<b>PARTS ILLUSTRATIONS.....</b>	<b>50</b>
7.1	Hoist Gearbox Components .....	50
7.2	C16 / C20 / C25 Hoist Motor & Brake Assembly.....	52
7.3	Lifting Assembly – C16 Only .....	54
7.4	Lifting Assembly – C20/25 Only .....	56
7.5	C16 / C20 / C25 Electrical Control Assembly.....	58
7.6	Double Brake (Option) C16 / C20 / C25.....	60
7.7	Push Button Assembly – Horizontal Pairs of Buttons.....	61
7.8	Push Button Assembly – Horizontal Pairs of Buttons.....	62
7.9	Push Button Assembly – Vertical Pairs of Buttons (Option).....	63
7.10	Push Button Assembly – Vertical Buttons (Option).....	65

---

# 1 INTRODUCTION

## 1.1 Contact Information

Please do not hesitate to use for following contact information in the event that you may need assistance:

**Konecranes**

**4505 Gateway Boulevard**

**Springfield, OH 45502**

**General Telephone: 937 - 525-1190**

**Toll Free Telephone (US): 866 - 291-1754**

**General Fax: 937 - 328-5165**

## 1.2 Warranty

All sales are subject to the Konecranes [Standard Terms and Conditions of Sale and Product Warranty](#). Copies are available upon request from Konecranes and are expressly incorporated by reference hereto.

## 1.3 Disclaimer

This Manual has been prepared by **Konecranes** to provide information and suggestions for hoist installation, maintenance, and inspection personnel. This manual should be used in conjunction with the **XN Electric Chain Hoist Operator's Manual** to teach safe operating practices to all personnel associated with hoist operations and maintenance.

It is **NOT** intended that the recommendations in this manual take precedence over existing plant safety rules and regulations or OSHA regulations. However, a thorough study of the following information should provide a better understanding of proper installation, maintenance, and inspection procedures that are to be followed in order to afford a greater margin of safety for people and machinery in the area of hoist operations.

It must be recognized that this is a manual of recommendations for the Hoist Installation, Maintenance, and Inspection personnel and its use is permissive not mandatory. It is the responsibility of the hoist owner to make personnel aware of all federal, state, and local codes and regulations. The owner is responsible for providing instruction and insuring that certain installation, maintenance, and inspection personnel are properly trained.

## 1.4 Safety



**Read and understand this manual before using the hoist.**

Important issues to remember during installation, operation, maintenance, and inspection are provided at the hoist control stations, at various locations on the hoist, in this manual, and in the [XN Electric Chain Hoist Operator's Manual](#). These issues are indicated by **DANGER**, **WARNING**, or **CAUTION** instructions or placards that alert personnel to potential hazards, proper operation, load limitations, and more.

### *m*

**DANGER:** Indicates an imminently hazardous situation, which, if not avoided, will result in death or serious injury.

### *m*

**WARNING:** Indicates a potentially hazardous situation, which, if not avoided, could result in death or serious injury.

### *m*

**CAUTION:** Indicates a potentially hazardous situation, which, if not avoided, may result in minor or moderate injury. It may also be used to alert against unsafe practices.

**Taking precedence over any specific rule, however, is the most important rule of all:**

**“USE COMMON SENSE”**

It is a responsibility of the hoist owner / user to establish programs to:

1. Train and designate hoist operators, and
2. Train and designate hoist inspectors / maintenance personnel.

---

The words **SHALL** and **SHOULD** are used throughout this manual in accordance with definitions in the ASME B30 standards as follows:

**SHALL** indicates a rule is mandatory and must be followed.

**SHOULD** indicates a rule is a recommendation, the advisability of which depends on the facts in each situation.

Hoist operation, hoist inspection, and hoist maintenance personnel training programs should be based on requirements in accordance with the latest edition of:

- **ASME B30.16 Safety Standard for Overhead Hoists ( Underhung )**

Such training should also provide information for compliance with any Federal, State, or Local Code requirements, and existing plant safety rules and regulations.

If an overhead hoist is installed as part of an overhead crane or monorail system, training programs should also include requirements in accordance with the latest editions, as applicable, of:

- **ASME B30.2 Safety Standard for Overhead and Gantry Cranes, Top Running Bridge, Single or Multiple Girder, Top Running Trolley Hoist**
- **ASME B30.11 Safety Standard for Monorails and Underhung Cranes**
- **ASME B30.17 Safety Standard for Overhead and Gantry Cranes, Top Running Bridge, Single Girder, Underhung Hoist.**

**NOTICE:**



It is a responsibility of the owner / user to install, inspect, test, maintain, and operate a hoist in accordance with the ASME B30.16 Safety Standard, OSHA Regulations, and ANSI / NFPA 70, National Electric Code. If the hoist is installed as part of a total lifting system, it is also the responsibility of the owner / user to comply with the applicable ASME B30 volume that addresses other types of equipment used in the system.



Further, it is the responsibility of the owner / user to require that all personnel who will install, inspect, test, maintain, and operate a hoist read the contents of this manual, **XN Electric Chain Hoist Operator's Manual**, ASME B30.16 Safety Standards for Overhead Hoists (Underhung), OSHA Regulations, and ANSI / NFPA 70, National Electric Code. If the hoist is installed as part of a total lifting system, all personnel must also read the applicable ASME B30 volume that addresses other types of equipment used in the system.

**!!! DANGER:** Failure to read and comply with any one of the limitations noted in this manual can result in product failure, serious bodily injury or death, and / or property damage.

Konecranes has no direct involvement or control over the hoist's operation and application. Conforming to good safety practices is the responsibility of the owner, the user, and its operating personnel.

Only those Authorized and Qualified Personnel who have shown that they have read and have understood this manual and the **XN Electric Chain Hoist Operator's Manual** should be permitted to operate the hoist.

The owner / user **SHALL** insure that all Operators read and understand the **XN Electric Chain Hoist Operator's Manual** prior to operating the hoist.

## 1.5 Placards and Instructions

READ and OBEY all Danger, Warning, Caution, and Operating Instructions on the hoist and in this manual and **XN Electric Chain Hoist Operator's Manual**. Make sure that all placards are in place and legible.

Failure to comply with safety precautions in this manual and on the hoist is a safety violation that may result in serious injury, death, or property damage.



## 2 INSTALLATION

***m*** **DANGER:** Before installing, removing, inspection, or performing any maintenance on a hoist, the main switch shall be de-energized. Lock and tag the main switch in the de-energized position in accordance with ANSI Z244.1. Follow other maintenance procedures outlined in this manual and ASME B30.16.

### 2.1 General

Prior to installation, the unit shall be checked thoroughly for damage during shipment or handling at the job site.

Each complete electric chain hoist is load tested at the factory at 125% of the nameplate-rated capacity.

All hoists are designed for the type of mounting specified by the purchaser. The adequacy of the supporting members (monorail beams, cranes, hangers, supports, framing, etc.) is the responsibility of user / owner and shall be determined or verified by qualified personnel.

Read the instructions contained in this manual and the [XN Electric Chain Hoist Operator's Manual](#) as well as any other related manuals. Observe the warning tags attached to the unit before the installation is started.

### 2.2 Chain Container Installation

***m*** **CAUTION:** REMOVE SMALL CHAIN CONNECTING CHAIN CONTAINER TO HOIST BODY. THIS CHAIN IS TO BE USED ONLY DURING INSTALLATION AND THEN MUST BE REMOVED.

Due to the weight of the chain and chain container on all Models [XN 16 / 20 / 25](#), the chain container is attached to hoist body with a LIGHT DUTY chain to facilitate removing hoist and chain container from packing container for assembly of chain container to hoist body.

### 2.3 Lubrication

The hoist gear case comes completely pre-lubricated with grease.

 **Note:** Open trolley wheel gearing has not been greased at the factory. See the trolley manual for proper gear lubricant to use before installing hoist.

The load chain requires lubrication prior to first use. Chain lubricant is included with shipment of each new chain hoist.

## 2.4 Mounting

Below are three types of mounting:

1. Hook Mounted
2. Base Mounted
3. Coupling Mounted
4. Trolley Mounted – NOT SHOWN – is accomplished via a Hook or Trolley Coupling to the Trolley Assembly.

**Figure 2.1. Mounting Types**

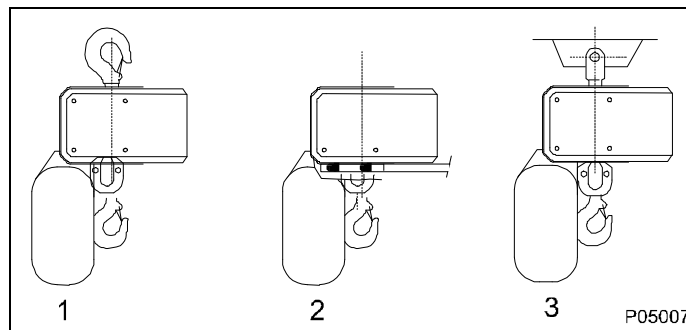

For all trolley-mounted hoists, refer to appropriate trolley manual for trolley installation instructions.

After a trolley-mounted hoist has been assembled to a beam, check for balance. Each trolley-mounted hoist is balanced at the factory for “as shipped” condition. Any auxiliary devices (radio control, lights, hose reels, etc.) furnished and mounted by “others” may require additional counterweight. Hoists must hang straight without a load or there will be a noticeable “kick” when a load is applied to hook. An unbalanced hoist / trolley may result in damage to equipment.

## 2.5 Load Hook Throat Opening

**⚠ CAUTION: ANSI B30.16-1998 recommends that the throat opening of a load hook be measured and recorded prior to putting a hoist into service and that a gage be made to provide a quick visual inspection for a bent hook as required during routine inspections.**

**⚠ CAUTION: Record this information before initial start-up. See Section 5.20 for more detailed hook information.**

## 2.6 Electrical Connection

The user / owner must provide the main power supply hardware (cable, conductor bar, fuses, disconnect switch, etc.).

- m*** CAUTION: Make sure that the power supply voltage is the same as that shown on hoist serial plate / nameplate.
  
- m*** CAUTION: Make sure that fuses and other current overload devices are in place to protect the power supply.
  
- m*** CAUTION: Make sure that power cable or conductors have sufficient capacity to maintain the hoist supply voltage by  $\pm 5$  percent of nominal voltage under all operating conditions. Poor voltage regulation may cause motor overheating or sluggishness, and chattering / inoperative motor brake(s) and controls.
  
- m*** CAUTION: Do not use power supply cables with solid conductors.

## 2.7 Three Phase Power Connections

Figure 2.2. Three Phase Control Box Power Connections

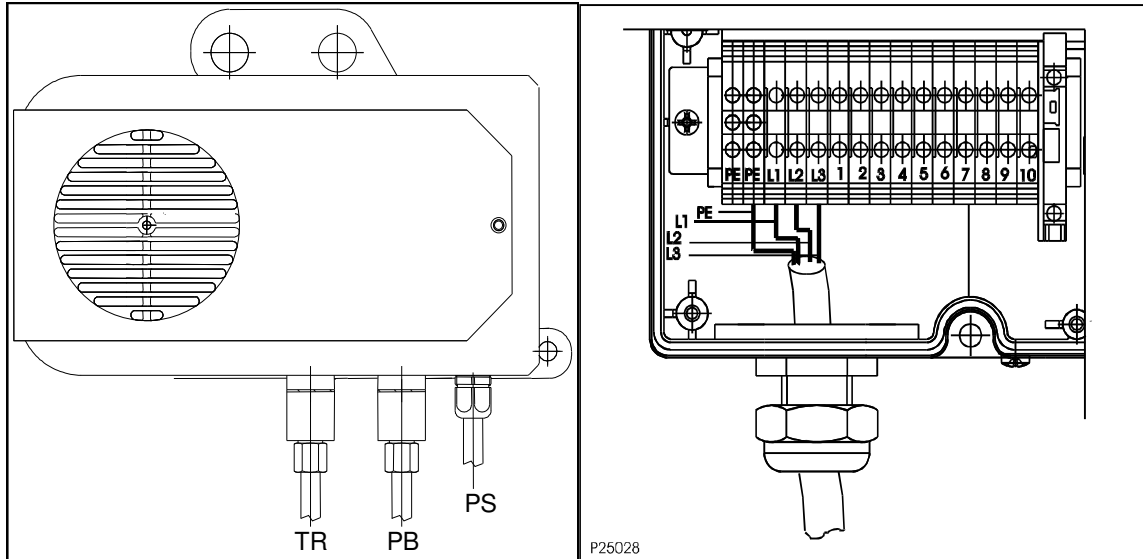

**PS – Power supply**

**TR – Trolley connection**

**PB – Pushbutton connection**

1. Remove the control enclosure cover.
2. Insert the power supply cable through the cable gland or connector (PS).
3. Connect phases L1, L2, L3, and ground (PE) to terminal strip. Refer to the wiring diagram.
4. Tighten the terminal screws
5. Tighten the cable gland or connector to secure the cable.
6. Connect the pushbutton assembly to plug connector X23 (PB).
7. Connect the motorized trolley plug connector X24 (TR) (optional).
8. Close the control enclosure cover.

### 3 INITIAL START-UP

**!!! WARNING:** Before connecting power to hoist, check all “motion” buttons on pendant control assembly to make sure that they operate freely without binding or sticking. Check pendant cable and strain relief connection to ensure that they are not damaged.

#### 3.1 General

Initial start-up procedures are as follows:

- Read all attached **WARNING** tags and placards affixed to hoist.
- Oil load chain generously over entire length of chain.
- Make sure that load chain is not twisted. If so, untwist load chain before using.
- Make sure fall stop is placed at least 6” [150 mm] from last chain link on free end.
- Install chain container.
- If furnished, make sure that trolley wheels have proper spacing in relation to beam flange. See appropriate trolley manual for details.
- Check direction of hook travel to make certain that it corresponds to respective control button that is depressed. That is, does hook travel “**UP**” when **UP BUTTON** is depressed? If OK, go to section 3.3. If not, proceed to section 3.2 for correcting direction of travel.

#### 3.2 Correcting the Direction of Hook Travel

**!!! WARNING:** **DO NOT** change control leads in pushbutton enclosure or at motor relays. **DO NOT** change nameplates on pushbutton assembly. The upper/lower safety limit switch is wired in series with “**UP**” control circuit as furnished from factory. Changing pushbutton control leads or nameplates will prevent the upper safety travel limit switch from functioning properly.

Reversing any two power leads of a three-phase AC motor will reverse the direction of rotation.

- Reverse any two leads of a three-phase power at the main power source or at connections to motor. **Do not change internal wiring of hoist.**
- After changing two of the main power leads, recheck direction of rotation. Press “**UP**” button only. If hook travel goes in “**UP**” direction, proceed to section 3.3. If not, redo section 3.2.

---

### 3.3 Operational Checks – No Load

- Check hoist motor brake function. Run empty load block up or down to check that load block does not drift more than 1.0 inch [25mm]. If so, adjust brake as described in Section 5.3 of this manual.
- Run empty load block down to check that fall stop (located on free end of load chain) makes proper contact with upper / lower travel safety limit switch and that limit switch functions properly.
- Run empty load block up to check that load block makes proper contact with upper / lower travel safety limit switch and that limit switch functions properly.
- Run empty load block up and down several times while checking for proper tracking of load chain.

### 3.4 Operational Checks – With Load

- After completion of no-load operational tests, the user /owner should perform a full load test even though each complete hoist is load tested at factory.
- Lift a near capacity load about one (1) foot [30cm] above floor level. Check that the brake holds load. Also, check stopping capability of brake when lifting to a stop and lowering to a stop.
- Move trolley the full length of monorail or crane beam. Check for any binding of trolley wheels on flange and/or interference at splice joints, hanger connections / bolts, etc.
- Check contact with stops. Contact with stops **SHALL** only be made with trolley bumpers. Stops that are designed to make contact with wheels **SHALL NOT** be used.

---

## 4 HOIST OPERATION

- !!!*** WARNING: BEFORE PROCEEDING WITH THE NORMAL OPERATION OF THIS HOIST, THE OPERATOR/(S) SHALL BE TRAINED IN ACCORDANCE WITH THE **XN Electric Chain Hoist Operator's Manual** AS SUPPLIED WITH THIS HOIST.
  
- !!!*** WARNING: FAILURE TO READ AND COMPLY WITH ANY ONE OF THE LIMITATIONS NOTED IN THIS MANUAL AND THE **XN Electric Chain Hoist Operator's Manual** FURNISHED WITH THIS HOIST CAN RESULT IN PRODUCT FAILURE, SERIOUS BODILY INJURY OR DEATH, AND / OR PROPERTY DAMAGE.
  
- !!!*** WARNING: REFER TO SECTION 1.0 OF THIS MANUAL FOR CONTACT INFORMATION IF ADDITIONAL ASSISTANCE IS NEEDED.

**THIS PAGE INTENTIONALLY LEFT BLANK**



## 5 MAINTENANCE

### 5.1 Basic Hoist Construction

*Figure 5.1. Basic Hoist Components*

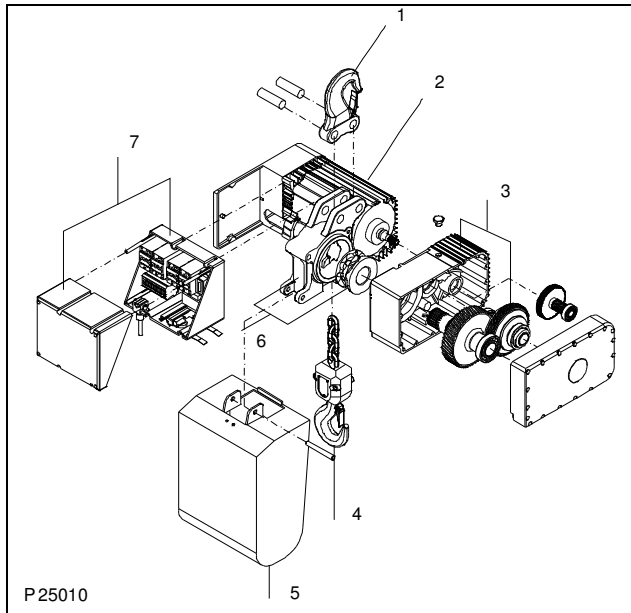

1. TOP HOOK
2. HOIST MOTOR
3. GEAR CASE & GEARING
4. LOAD BLOCK ASSEMBLY
5. CHAIN CONTAINER
6. CHAIN SPROCKET
7. CONTROLS & ENCLOSURE

## 5.2 Hoist Motor and Brake Assembly

The hoist motors are designed to provide dependable hoisting service. The standard motors are enclosed for IP55 rated protection against normal hazards of dust and moisture. The motor bearings are sealed and do not require further greasing.

**!!! DANGER:** Before installing, removing, inspection, or performing any maintenance on a hoist, the main switch shall be de-energized. Lock and tag the main switch in the de-energized position in accordance with ANSI Z244.1. Follow other maintenance procedures outlined in this manual and ASME B30.16.

*Figure 5.2. Hoist Motor and Brake Assembly*

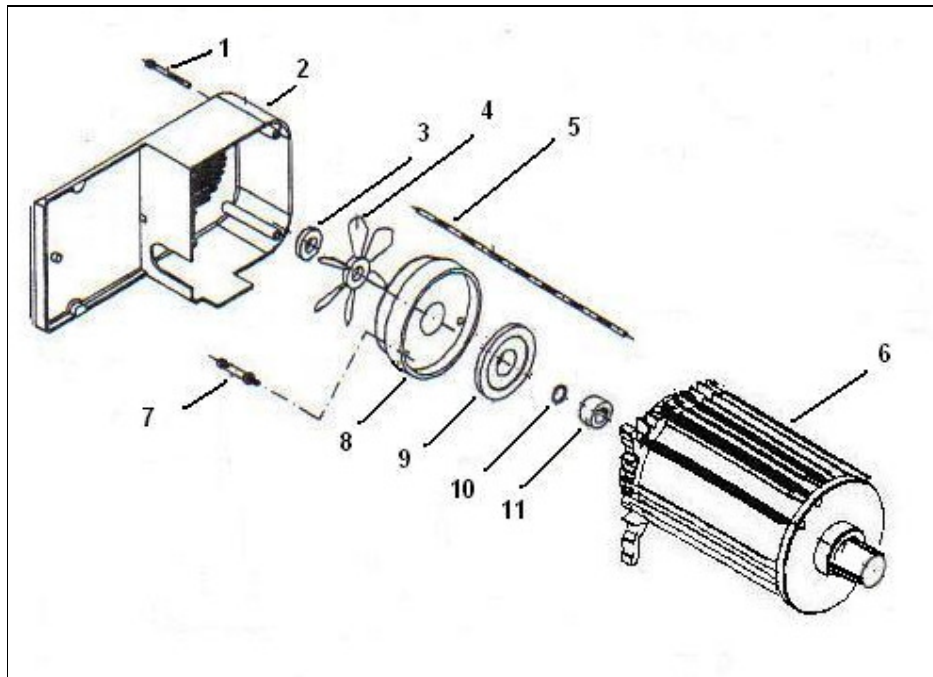

1. Hex head cap screw – three (3)
2. Brake and fan cover
3. Fan lock collar
4. Fan
5. Motor mounting bolt / threaded rod – three (3)
6. Hoist motor
7. Hex head cap screw – three (3)
8. Motor brake assembly
9. Friction rotor
10. Snap ring
11. Brake hub

**Remove Hoist Motor and Brake Assembly (refer to Figure 5.2)**

1. Remove load from load block assembly.
2. Raise load block assembly to hoist body. Allow slack in chain to permit tying up bottom block assembly to remove weight of bottom block assembly from load chain.
3. Remove and lockout power to the hoist.
4. Remove three-sided branding cover.
5. Remove three (3) screws (item 1) and take off Brake and Fan Cover (item 2).
6. Remove brake coil leads from terminals inside hoist electrical control enclosure.
7. Loosen brake cable gland on electrical control enclosure and pull out brake cable.
8. Remove hoist motor leads from K25 and K10 contactors located in hoist electrical control enclosure.
9. Loosen motor cable gland on electrical control enclosure and pull out motor leads.
10. Remove screws and remove electrical control enclosure from hoist motor.
11. Remove screw and remove mounting bracket from hoist motor.
12. Remove three lock nuts from threaded rods (item 5) and pull hoist motor and brake assembly out away from gearbox.

**Installing Hoist Motor and Brake Assembly (refer to Figure 5.2)**

1. Mount hoist motor to gearbox making sure hoist motor is positioned properly. Push hoist motor into gearbox until tight and threaded rods (item 5) are through end flange of hoist motor.
2. Use lock nuts to draw hoist motor in place against the gearbox. Tighten lock nuts evenly as the hoist motor moves into place.
3. Mount brackets to hoist motor and tighten socket head cap screw.
4. Mount electrical control enclosure to hoist motor and tighten four (4) screws.
5. Insert hoist motor cable through motor cable gland on electrical control enclosure and reconnect motor leads to K25 and K10 contactors. Tighten hoist motor cable gland.
6. Insert hoist motor brake leads through brake cable gland on electrical control enclosure and reconnect hoist motor brake leads. Tighten hoist motor brake cable gland.
7. Recheck tightness of lock nuts holding hoist motor.
8. Mount end cap and tighten socket head cap screws. (Do not over-tighten.)
9. Replace three-sided branding panel.
10. Untie the load block assembly.
11. Unlock power and turn on.
12. Press "UP" button and check for proper phase rotation. If not correct, turn off power and change position of two of the three power leads that were just reconnected.
13. If direction is correct, perform a no-load check and then a full load check per section 3.3 and 3.4 respectively.

**Hoist Motor Brake**

The hoist motor brake is a D.C. electromagnetic disc brake and does not require adjustment. The brake brings the load to a smooth and quick stop and holds the load when the hoist motor is not energized. An energized coil releases the hoist motor brake and permits the raising and lowering of the load.

**Figure 5.3. Hoist Motor Brake**

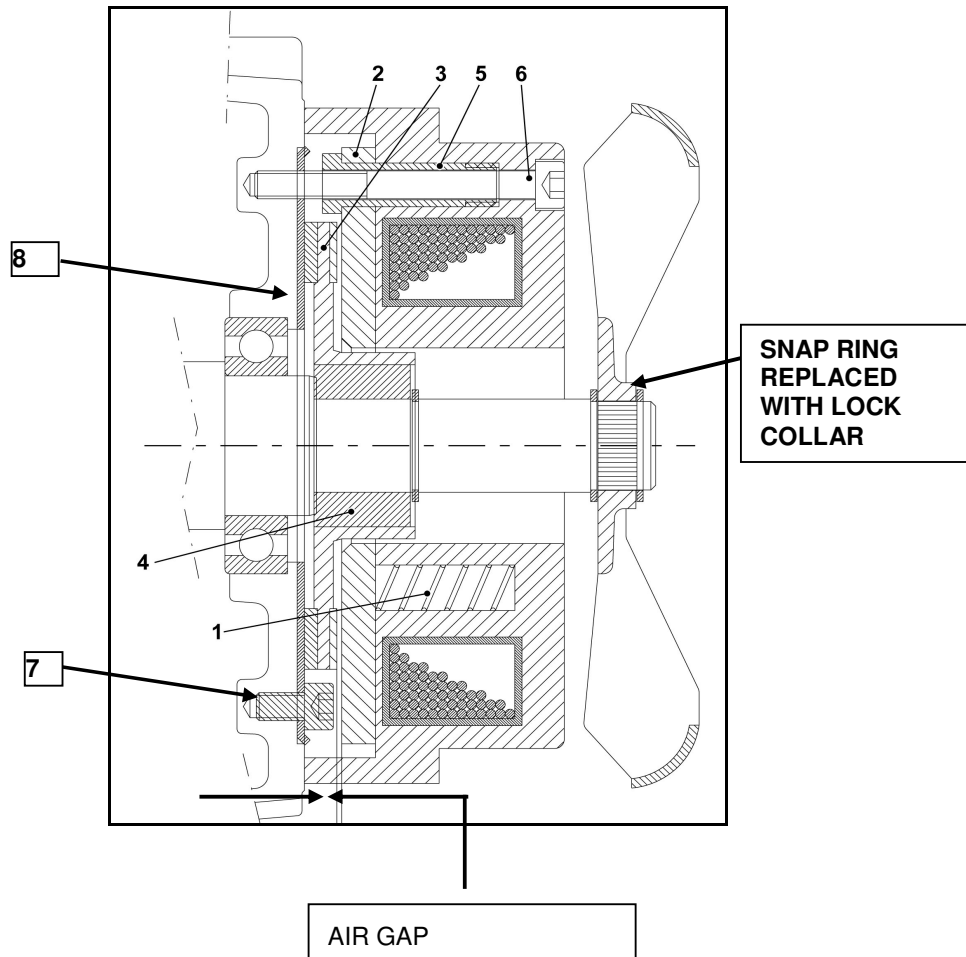

- 1. Brake Spring
- 2. Brake Armature Plate
- 3. Friction Rotor
- 4. Brake Hub
- 5. Brake Adjusting Rod
- 6. Brake Mounting Screw
- 7. Screw
- 8. Wear Plate

### 5.2.1 Replacement Criteria for Motor Brakes

Table 1. Replacement Criteria for Motor Brakes

	THICKNESS AS NEW	REPLACE WHEN
XN 01	0.260 inches (6.6 mm)	0.220 inches (5.6 mm)
XN 05	0.370 inches (9.4 mm)	0.330 inches (8.4 mm)
XN 10	0.055 inches (1.4 mm)	0.016 inches (0.4 mm)
XN 16	0.406 inches (10.3 mm)	0.366 inches (9.3 mm)
XN 20	0.406 inches (10.3 mm)	0.366 inches (9.3 mm)
XN 25	0.406 inches (10.3 mm)	0.366 inches (9.3 mm)

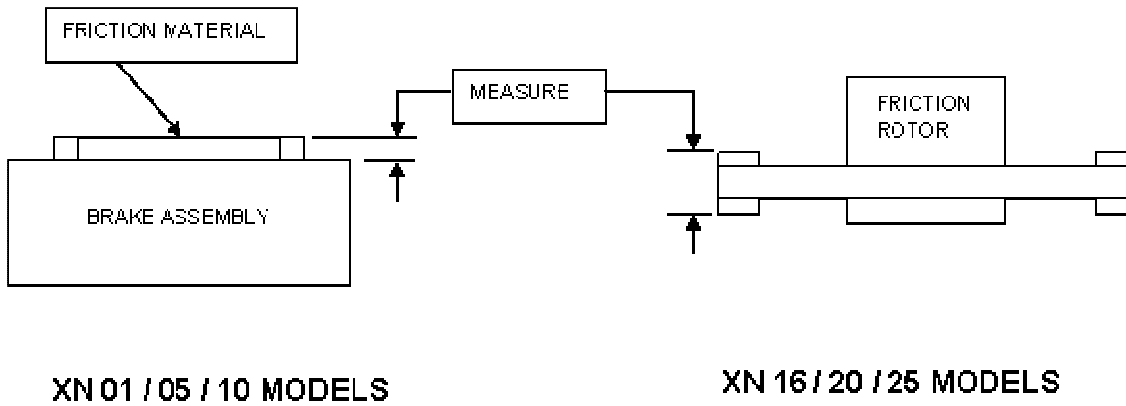



**NOTE: MAXIMUM ALLOWABLE GAP IS 0.5mm or 0.020 inches. Remove round plastic dust cap on the side of the brake assembly. Turn off power to hoist, insert gage pin of proper diameter to check motor brake gap. Recommend that a gage pin set be available with increments of 0.001" ranging from 0.015" to 0.020".**



**Gap may be measured periodically to predict replacement based upon frequency of use. Replace the friction rotor when the gap reaches the maximum allowable dimension.**

### Removing Hoist Motor Brake (Refer to Figures 5.2 and 5.3)

1. Remove load from load block assembly.
2. Raise load block assembly to hoist body. Allow slack in chain to permit tying up bottom block assembly to remove weight of bottom block assembly from load chain.
3. Remove and lockout power to the hoist.
4. Remove three-sided branding cover.
5. Remove three (3) screws (item 1- figure 5.2) and take off Brake and Fan Cover (item 2-figure 5.2).
6. Remove lock collar (see Figure 5.3) and remove fan. If needed, use two screwdrivers under hub to pry fan loose.
7. Remove second retaining ring and pull out spacer.
8. Remove brake coil leads from terminals inside hoist electrical control enclosure.
9. Loosen brake cable gland and pull out brake cable as necessary.
10. Remove three (3) screws – Figure 5.3 - from brake magnetic assembly. Remove brake magnetic assembly.
11. Remove motor brake friction rotor – item 3 – Figure 5.3.
12. Remove three (3) screws – item 7 – Figure 5.3 and remove wear plate item 8 – Figure 5.3.

### Installing Hoist Motor Brake (Refer to Figures 5.2 and 5.3)

1. Check the voltage of the motor brake assembly. It must match the voltage of the motor.
2. Attach wear plate – item 8 – Figure 5.3 to hoist motor end flange and tighten three (3) screws item 7 – Figure 5.3 to recommended tightening torque – 6.6 lb-ft [9Nm].
3. Slide friction rotor (item 3 – Figure 5.3) onto brake hub (item 4 – Figure 5.3).
4. Mount magnetic brake assembly (item 1 – Figure 5.3) and tighten three (3) screws (item 6 – Figure 5.3) to recommended tightening torque – 6.6 lb-ft [9 Nm].
5. Insert spacer and install snap ring into groove just above spacer.
6. Mount fan (item 4 – Figure 5.2) and install lock collar just above fan hub.
7. Insert motor brake leads through brake cable gland on electrical control enclosure and reconnect motor brake leads. Tighten motor cable gland.
8. Mount end cap and tighten three screws. (Do not over-tighten.)
9. Replace branding cover.
10. Turn on power.
11. Free the bottom block and make certain load chain is not twisted
12. Perform no-load test and load test per Sections 3.3 and 3.4 respectively.

### 5.3 Torque Limiter (Refer to *Figure 5.4*)

The hoist is equipped with a torque limiter that is located in the gearbox assembly. The torque limiter is a safety device that prevents lifting excessive loads that may damage to the hoist. The torque limiter is a friction type slip clutch that couples the motor to the gear train.

#### Torque Limiter Adjustment (Refer to *Figure 5.4*)

1. Remove three-sided branding panel.
2. Use two small straight-slot screwdrivers and remove plastic cap from center of gearbox cover.
3. Loosen locking screw (item 16).
4. Use a 46mm socket to turn the adjusting nut (item 15).
5. Turn clockwise to increase torque setting
6. Turn counter-clockwise to decrease torque setting
7. Set limiter equal to or 5 percent less than 125 percent of nameplate capacity.
8. Tighten locking screw (item 16).
9. Replace plastic cap.
10. Replace three-sided branding panel.

**Figure 5.4. Torque Limiter**

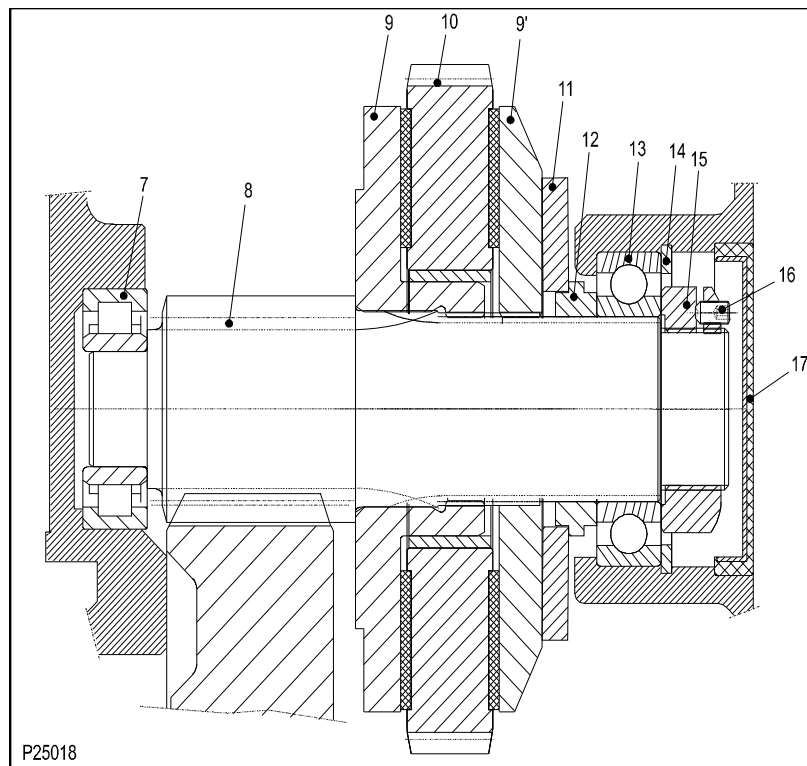

---

## 5.4 Load Chain

*m* **CAUTION:** A hoist **SHALL NEVER** be used if the load chain shows any evidence of mechanical damage or excessive wear. Never use the load chain as a sling. Use only original equipment chain as supplied by a factory authorized source. Improper load chain storage or installation can render the load chain unusable prior to the first lift.

## 5.5 Maintenance Inspection

A qualified person **SHALL** be designated to routinely conduct an in-depth inspection of the load chain (See Section 6 – Preventative Maintenance for schedule recommendations). This designated person **SHALL** inspect load chain using good judgment in evaluating the remaining service life. Any deterioration of load chain resulting in appreciable loss of original strength **SHALL** be noted and evaluated.

An in-depth inspection **SHALL** include a written record that is dated and signed by the inspector.



Figure 5.5. Chain Dimensions

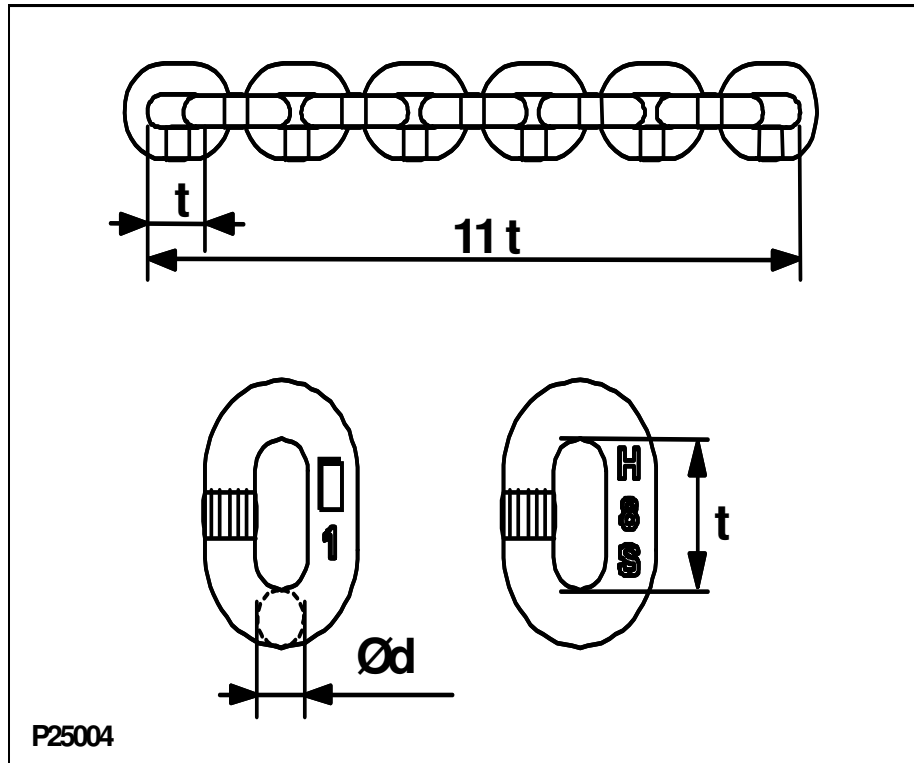

Measure the following chain dimensions at several points on chain: (Figure 5.5)

- Dimensions of one link (  $d \times t$  ) where,  $d$  = diameter and  $t$  = pitch
- Length over 11 links (  $11 t$  )

Replace load chain if any one of these dimensions exceeds maximum allowed wear:

		XN 16	XN 20 / 25
<b>Maximum allowed wear:</b>		<b>9.0 x 27.0 chain</b>	<b>11.3 x 31.0</b>
<b>Minimum link diameter allowed</b>	( $d$ ):	<b>0.319" [8.1 mm]</b>	<b>0.398" [10.1 mm]</b>
<b>Maximum pitch allowed</b>	( $t$ ):	<b>1.114" [28.3 mm]</b>	<b>1.280" [32.5mm]</b>
<b>Maximum length allowed</b>	( $11t$ ):	<b>11.929" [300 mm]</b>	<b>13.681" [347.5 mm]</b>

**NOTICE:**

 If load chain needs replaced, then inspect chain guide and chain (load) wheel on hoist and idler sprocket in 2-fall load block for excessive wear. A chain sprocket showing evidence of scored pockets or sharp edges generated from wear SHALL be replaced. A worn chain sprocket or idler sprocket can greatly reduce the life of load chain.

## 5.6 Load Chain Specifications (see *Figure 5.5*)

Table 2. Load Chain Specifications

	<b>XN 16</b>	<b>XN 20/LM25</b>
<b>Hoist Type:</b>	<b>XN 16</b>	<b>XN 20/LM25</b>
<b>Chain Specification:</b>	Load chain - 9.0 x 27.0	Load chain - 11.3 x 31.0
<b>Chain type:</b>	Standard	Standard
<b>Diameter (ød) x pitch (t):</b>	0.3543 x 1.0629 in [9.0 x 27.0 mm]	0.4449 x 1.2205 in [11.3 x 31.0 mm]
<b>Length over 11 links (11t):</b>	11.6929" [297 mm]	13.4251" [341 mm]
<b>Class:</b>	DAT	DAT
<b>Grade:</b>	H8S or HE G80 RAS	H8S or HE G80 RAS
<b>Maximum working stress:</b>	123.4 N/mm <sup>2</sup>	122.3 N/mm <sup>2</sup>
<b>Hardened surface:</b>	580 or 700 HV	580 or 700 HV
<b>Thickness:</b>	0.18 to 0.45 mm	0.21 to 0.52 mm
<b>Standard:</b>	DIN 5684 – 8	DIN 5684 - 8
<b>Marking (10 x t):</b>	1 or 16 H 8 S or A 8	1 or 16 H 8 S or A 8
<b>Maximum working load, 1 fall:</b>	3527 lbs. [1600 kg]	5511 lbs. [2500 kg]
<b>Breaking load:</b>	93 Kn	160 kN
<b>Maximum breaking stress:</b>	116,030 lbs/in <sup>2</sup> (800 N/mm <sup>2</sup> )	116,030 lbs/in <sup>2</sup> (800 N/mm <sup>2</sup> )
<b>Total breaking elongation:</b>	>10% min.	>10% min.
<b>Weight for 100 links:</b>	1.8 kg	2.85 kg

## 5.7 Removing the Load Chain

### 1-FALL CHAIN

1. Remove load from hook block assembly.
2. Remove load block assembly from load chain. Some disassembly of 1-fall load block is required.
3. Attach the chain insert tool to the end of bottom block end of the chain.
4. Run hoist in "UP" direction until all of chain is in container. Stop the hoist with the insertion tool remaining in the hoist ready for the new chain.
5. Remove chain container with all of old chain in chain container.
6. Remove fall stop from old chain and save for use with new chain.

### 2-FALL CHAIN

1. Remove load from hook block assembly.
2. Run hoist in "UP" direction until hook block assembly is about 1.0 foot [30cm] from hoist body.
3. Unfasten load chain from chain anchor mounted on hoist body.
4. Remove load block assembly from load chain by allowing chain to run through it. Attach the chain insertion tool to the bottom block end of the chain.
5. Run hoist in "UP" direction until all of the chain is in the container. Stop the hoist with the insertion tool remaining in the hoist ready for the new chain.
6. Remove chain container with old chain.
7. Remove fall stop from old chain and save for use with new chain.

## 5.8 Installing the Load Chain

Figure 5.6. Chain Installation

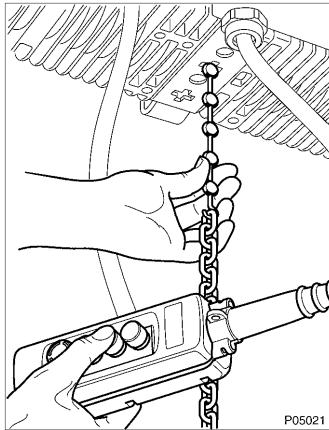
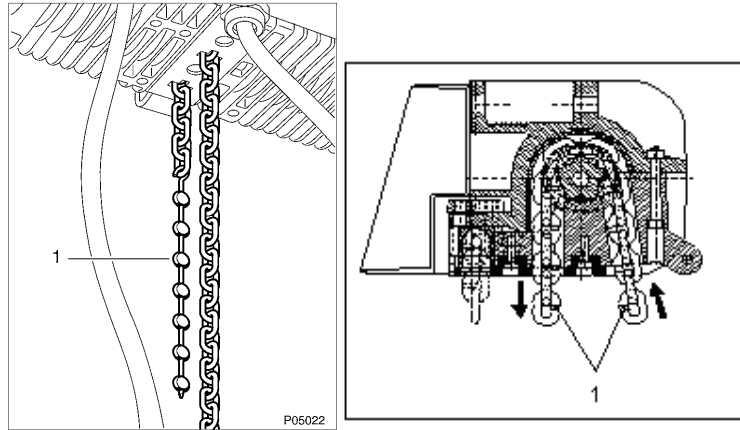

Figure 5.7. Chain Orientation



### 1-FALL CHAIN INSTALLATION

1. Attach last link of chain onto hook of CHAIN INSERTION TOOL (item 1, Figure 5.6).
2. If the insertion tool is not in the hoist (removal procedure), insert other end of CHAIN INSERTION TOOL into chain opening closest to chain container side.

***m* CAUTION: Make sure the chain weld on chain link faces inward toward chain wheel pocket on hoist load sprocket. See Figure 5.7.**

3. Run hoist "UP" in slow speed to feed chain through chain sprocket and out other side.
4. Attach fall stop at least 6.0 inches [150 mm] from end of chain (chain container side). Attach load block assembly on other end of load chain. Refer to Figure 5.8 for details.
5. Make sure that load chain is not twisted or deformed.
6. Attach chain container.

## **2-FALL CHAIN INSTALLATION**

1. If the chain insertion tool is not in the hoist (removal procedure), attach last link of chain onto hook of CHAIN INSERTION TOOL (item 1, *Figure 5.6*).
2. Insert other end of CHAIN INSERTION TOOL into chain opening closest to chain container.

***m*** **CAUTION: For a 2-Fall load block assembly, make sure the chain weld on chain link faces inward toward chain wheel pocket on hoist and away from idler sprocket of hook block assembly. See Figure 5.7. Follow steps outlined below:**

3. Run hoist in slow speed to feed chain through chain sprocket. Continue running until about 2.0 feet [60cm] of chain is available out the other side.
4. Slide chain onto idler sprocket of load block making sure not to twist chain while inserting it. Link weld must face away from idler sprocket on load block assembly.
5. Attach chain anchor and chain to hoist body. Tighten chain anchor bolts per recommended torque settings in Section 6.4.
6. Attach fall stop 6.0 inches [150 mm] from end of chain (chain container side). See *Figure 5.6* for details.
7. Make sure that chain is not twisted or kinked.
8. Attach chain container

### **After chain installation:**

1. Without a load, run chain up and down a few times to make sure load chain is not twisted. If so, remove chain twist.
2. Lubricate load chain.

## 5.9 Fall Stop Assembly (Refer to *Figure 5.8*)

The slack fall stop is a safety stop, not a functional stop. The fall stop must be located at least six (6.0) inches [150mm] from end of last chain link.

*Figure 5.8. Cross Section of Slack Fall Stop*

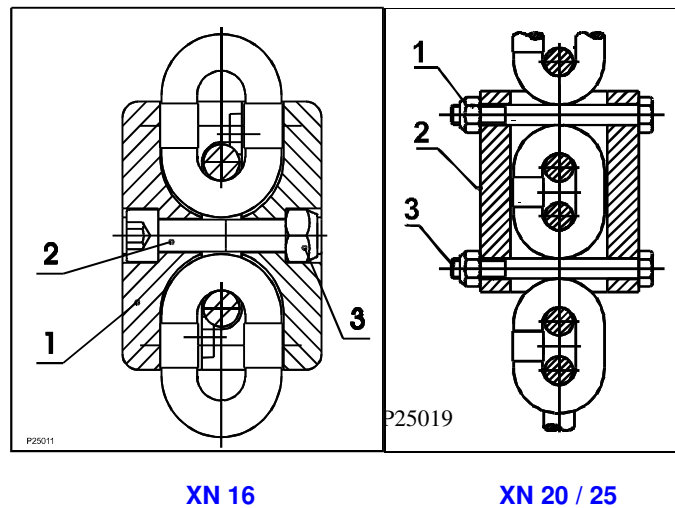

### Removing Fall Stop Assembly

1. Loosen and remove nut (two each for **XN 20/25**)
2. Remove bolts.
3. Remove two halves of Fall Stop.
4. Remove limit switch washer plate and spring.

### Installing Fall Stop Assembly

1. Install limit switch washer plate and spring unto chain. Make certain washer is in proper position to contact limit switch.
2. Place two halves of Fall Stop at least six (6) inches [150mm] from end of chain.
3. Insert bolt and tighten nut (two each for **XN 20/25**)

## 5.10 Chain Container

*Figure 5.9. Chain Container Installation*

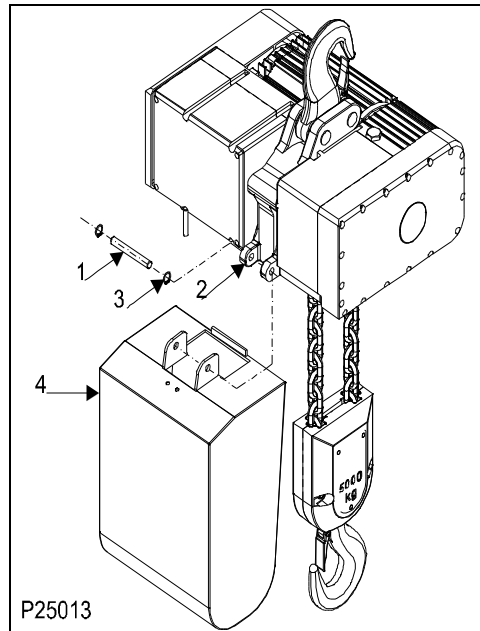

**CAUTION:** Chain container must be installed for effective operation of hoisting limit switch.

### Removing Chain Container (Figure 5.7)

1. Remove load from load block assembly.
2. Lower load block assembly to until a lowest point. This will remove weight of chain from chain container.
3. Support chain container before removing chain.
4. Remove snap ring (item 3) from end of pin (item 1). There is a snap ring on each end of pin.
5. Pull pin (item 1) out while supporting chain container (item 4).
6. Remove chain container (item 4).

### Installing Chain Container (Figure 5.7)

1. Place end of load chain into chain container (item 4). Position chain container (item 4) onto hoist mounting bracket (item 2).
2. Align holes and insert pin (item 1) through container (item 4) and hoist mounting bracket (item 2).
3. Install snap ring (item 3) on end of pin (item 1). Verify that snap ring is properly seated in groove on pin.
4. Raise load block and verify that chain is going into chain container without problems.

---

## 5.11 Upper and Lower Travel Safety Limit Switch

The Upper and Lower Travel Limit Switch is an automatic reset type switch and connected to the control circuit. The switch housing is recessed into the underside of hoist body.

***M* CAUTION: The primary limit device that controls the upper limit of travel is an emergency device only. It shall not be used as an operational means to stop travel during normal operations. Do not permit continuous contact between the hoist body and the load block / fall stop assembly.**

The hook block activates the upper limit switch as it contacts the limit switch that is located on bottom side of hoist body. Once the switch is activated, the “**UP**” circuit is opened. The fall stop activates the lower limit switch when hook block is lowered to its lowest travel position. The limit switch is activated and opens the “**DOWN**” circuit.

The lower limit position is adjustable between the lowest travel and maximum lift. It is adjusted by repositioning the fall stop assembly on free end of load chain. The fall stop **SHALL** always be located at least six (6) inches [150mm] from end of last chain link. The upper limit position is adjustable only when an additional fall stop assembly is added between the hook block assembly and the hoist body.

## 5.12 Upper and Lower Rotary Travel Limit Switch

The rotary limit switch is adjustable and provides over-travel protection for the upper and lower limits of hoist travel. The limit switch is connected to the control circuit.



**Note: Rotary limit switch assembly cannot be added to a Hoist. The Hoist must have the rotary limit switch assembly provided at time of initial production.**

### Adjustment

The position of the air-gap between the two discs (red – gray) determines the stopping place. This position can be found by gently turning the two discs. The length of air gap determines length of reset play in opposite direction.

Figure 5.9

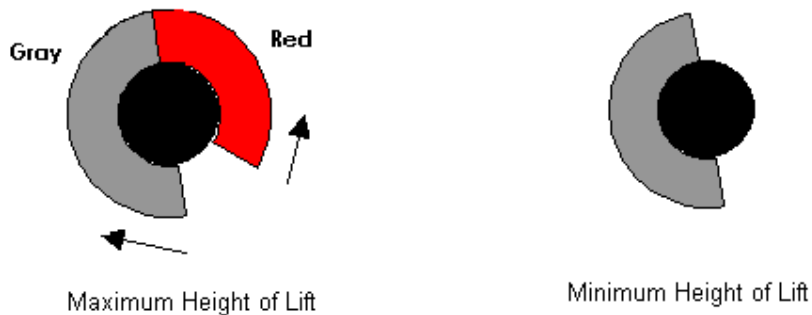

**To reset the rotary limit once it has tripped, the load block assembly must travel approximately 11” [27cm] in opposite direction.**



## 5.13 Hooks

Check hooks for deformation or cracks. Hooks must be replaced if throat opening has increased by more than 15%, or if throat opening has more than 10-degree twist from plane of straight hook.

**Figure 5.10. Measuring Hook Deformation**

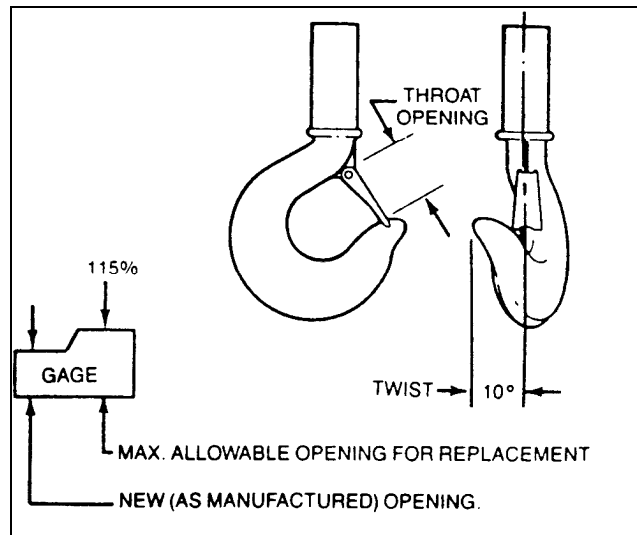

Due to many types and sizes of hooks that can be furnished and/or specified by the user / owner, it is recommended that user / owner measure the actual throat opening of hook as originally furnished. See *Figure 5.10*. Record the throat dimension on above sketch. Retain as a permanent record. This record can then be used for determining when hook must be replaced due to deformation or excessive throat opening.

- ⚠ CAUTION: Abuse or overloading of hoist is indicated when any hook is twisted or has a throat opening in excess of normal. Other load bearing components SHALL be checked for damage.**
- ⚠ CAUTION: Safety latches SHALL be replaced if missing, bent, or broken.**
- ⚠ CAUTION: A safety latch SHALL function properly at all times.**
- ⚠ CAUTION: Repairing hooks by welding or reshaping is strictly forbidden.**

## 5.14 Hook Inspection

The wear on the top hook and the load hook shall be checked routinely. Measure the throat opening (dimension  $a_2$ ). If the throat opening exceeds the maximum opening allowed ( $1.15 \times a_2$ ), replace the hook. Damaged safety latches shall be replaced immediately.

### Maximum throat opening allowed:

Hook class:	05T	08T	1T	16T	Top Hook
Maximum allowed opening:	1.54" [39mm]	1.69" [43mm]	1.81" [46mm]	2.01" [51mm]	2.13" [54mm]

## 5.15 Hook Dimensions

Figure 5.11. Hook Dimensions

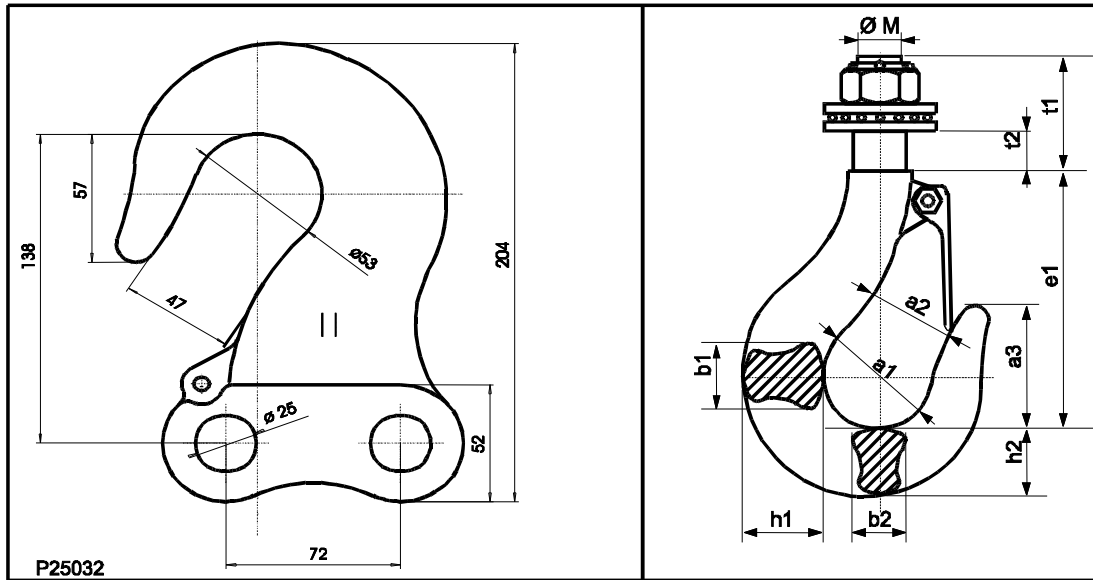

Table 3. Hook Dimensions

Hook Data					Dimensions inch / [mm]											
Cap Ton	Cap kg	Test lbs	Hoist Fall	Hook Class	ØM	Ø a1	Øa2	a3	b1	b2	e1	h1	h2	t1	t2	Øa2 max
1 1/2	1600	7055	XN 16 1	05 T	0.787 [20]	1.693 [43]	1.339 [34]	1.929 [49]	1.412 [29]	0.945 [24]	4.134 [105]	1.457 [37]	1.220 [31]	1.693 [43]	0.551 [14]	1.535 [39]
2	2000	8818	XN 20 1	08 T	0.945 [24]	1.890 [48]	1.496 [38]	2.125 [54]	1.378 [35]	1.142 [29]	4.528 [115]	1.732 [44]	1.457 [37]	2.087 [53]	0.709 [18]	1.693 [43]
2 1/2	2500	11023	XN 25 1	08 T	0.945 [24]	1.890 [48]	1.496 [38]	2.125 [54]	1.378 [35]	1.142 [29]	4.528 [115]	1.732 [44]	1.457 [37]	2.087 [53]	0.709 [18]	1.693 [43]
3	3200	14110	XN 25 1	08 T	0.945 [24]	1.890 [48]	1.496 [38]	2.125 [54]	1.378 [35]	1.142 [29]	4.528 [115]	1.732 [44]	1.457 [37]	2.087 [53]	0.709 [18]	1.693 [43]
			XN 16 2	1 T	0.945 [24]	1.969 [50]	1.575 [40]	2.244 [57]	1.496 [38]	1.26 [32]	4.724 [120]	1.89 [48]	1.575 [40]	2.323 [59]	0.945 [24]	1.811 [46]
4	4000	17637	XN 20 2	16 T	1.181 [30]	2.205 [56]	1.772 [45]	2.520 [64]	1.772 [45]	1.496 [38]	5.315 [135]	2.205 [56]	1.890 [48]	2.638 [67]	0.945 [24]	2.008 [51]
5	5000	22046	XN 25 2	16 T	1.181 [30]	2.205 [56]	1.772 [45]	2.520 [64]	1.772 [45]	1.496 [38]	5.315 [135]	2.205 [56]	1.890 [48]	2.638 [67]	0.945 [24]	2.008 [51]

Mark: ISO 2766

DIN model number: 15401

DIN 15400 class: T

DIN 15401 material: 35 CD 4

## 5.16 Top Hook

Figure 5.12. Top Hook Orientation

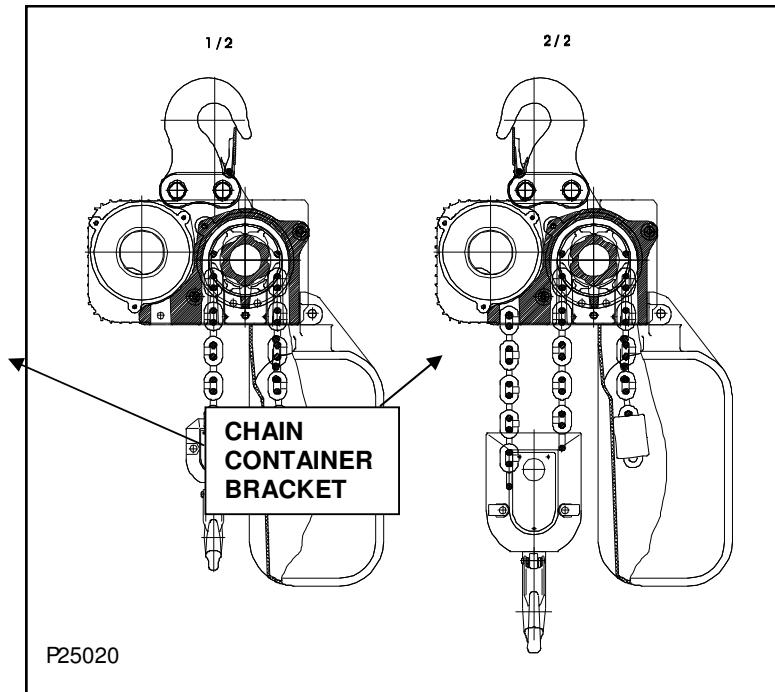

**CAUTION:** Before removing Top Hook, de-energize the power to the hoist per ANSI Z244.1 and make certain that any load is removed from the load hook. Also support the total weight of the hoist, including chain, prior to removing the Top Hook.

### Removing Top Hook

1. Place hoist on workbench. Protect limit switches on bottom of hoist.
2. There are two pins holding top hook in place. Remove retaining ring and washer on one end of each pin.
3. Pull pins out and remove hook. Keep washers and snap rings.

**CAUTION:** Proper installation of top hook is critical for hoist balance.

### Installing Top Hook

1. Place hoist on workbench. Protect limit switches on bottom of hoist.
2. Verify if hoist is 1-fall or 2-fall configuration. The hook is symmetrical and can be positioned two different directions. It is important to place top hook in correct position. Verify position of top hook with the above drawing.
3. Place top hook in location. Install pins and retaining hardware. Verify that a snap ring and washer is securely in place on each end.

## 5.17 Controls

The two-speed hoists are available for 208, 230, 460, 575 Volt - three-phase – 60 hertz power supplies. The controls of the two-speed hoists are NOT re-connectable because the hoist motors are voltage specific.

Note: The controls of the motorized trolley drive are not voltage re-connectable. Consult the motorized trolley manual if a voltage changeover is required.

### Control Circuit Fuses

The PC board control on the hoist includes a fuse (F100) for control circuit protection.

Table 4. Control Circuit Fuse

Control Voltage	Size
115 VAC	1.25 A
48 VAC	1.25 A

Table 5. Control Circuit Components, Terminals, and Connections.

Power & Motor Supply			Pushbutton	X23 Plug Pin No:		Function	
						Terminal	
L1	Hoist Supply						
L2	Hoist Supply		Common	X23: 1		1-2	Thermal protection
L3	Hoist Supply		Up	X23: 2		2-3	Upper limit switch
K21-2	(-) Brake		Down	X23: 3		4-5	Lower limit switch
K21-4	(+) Brake		Hoist Fast	X23: 4		<b>ID</b>	<b>Description</b>
K10-1	U1-U2 Motor Supply		E-Stop	X23: 5		K10	E-stop contactor
K25-R3	1V Motor Supply		Trolley Right	X23: 6		K21	Up contactor
K25-3	2V Motor Supply		Trolley Left	X23: 7		K22	Down contactor
K25-R1	1W Motor Supply		Trolley Fast	X23: 8		K25	Hoist fast contactor
<b>Ground</b>						T100	Transformer
PE	Motor	<b>Terminal</b>		<b>X24 Plug Pin No:</b>		F100	Fuse
PE	K10						
PE	Trolley Connection	X1: 9	Control voltage	X24: 1			
PE	Power Supply	X1: 10	SD: low speed	X24: 2			
		X1: 8	F: Trolley Fast	X24: 3			
		X1: 7	D1: Trolley Rev	X24: 4			
		X1: 6	D2: Trolley Fwd	X24: 5			

### Control Panel Layout

Figure 5.13. Printed Control Circuit (2 Lifting Speeds with Emergency Stop)

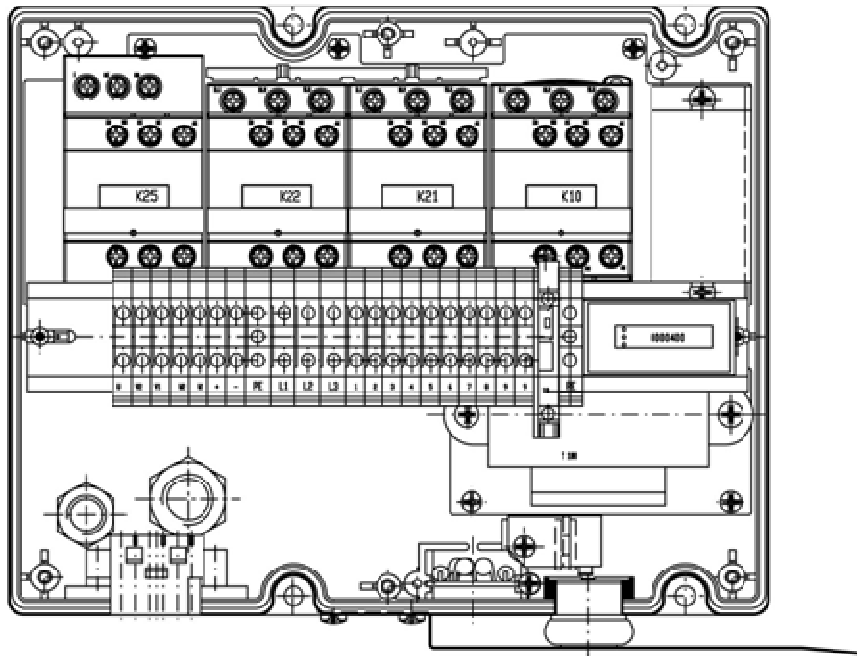

### 5.18 Two Speed – Three Phase – 208 / 230 / 460 Volt – Power Circuit

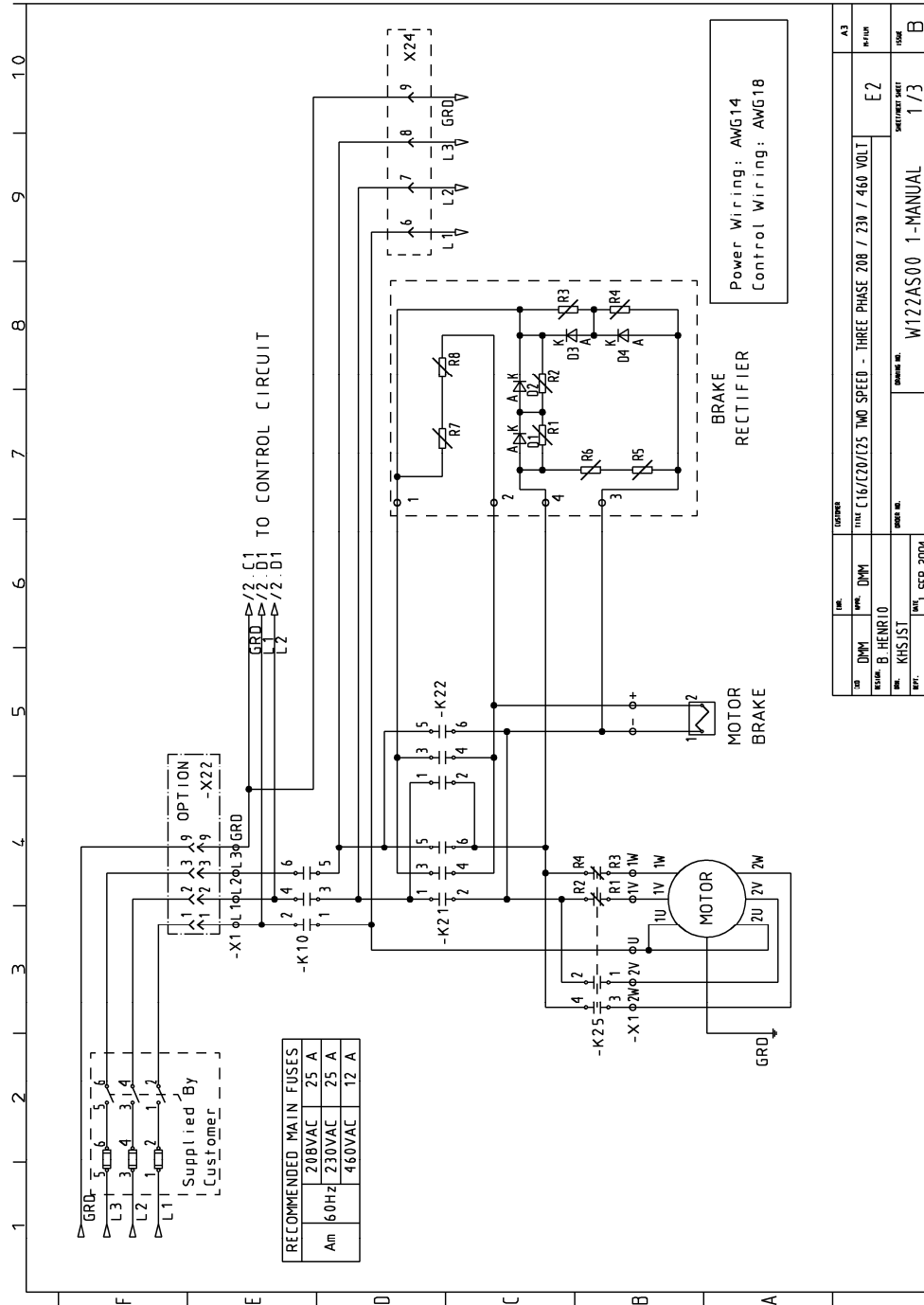

REV.	DATE	BY	CHKD.	DESCRIPTION
01	DMY	B. HENRIO		TITLE C16/C20/C25 TWO SPEED - THREE PHASE 208 / 230 / 460 VOLT
02	KHS/JST			BRAND NO. W122AS00_1-MANUAL SHEET NO. 1/3
				DATE: 1 SEP 2004
				SCALE: B

### 5.19 Two Speed – Three Phase – 208 / 230 / 460 Volt – Control Circuit

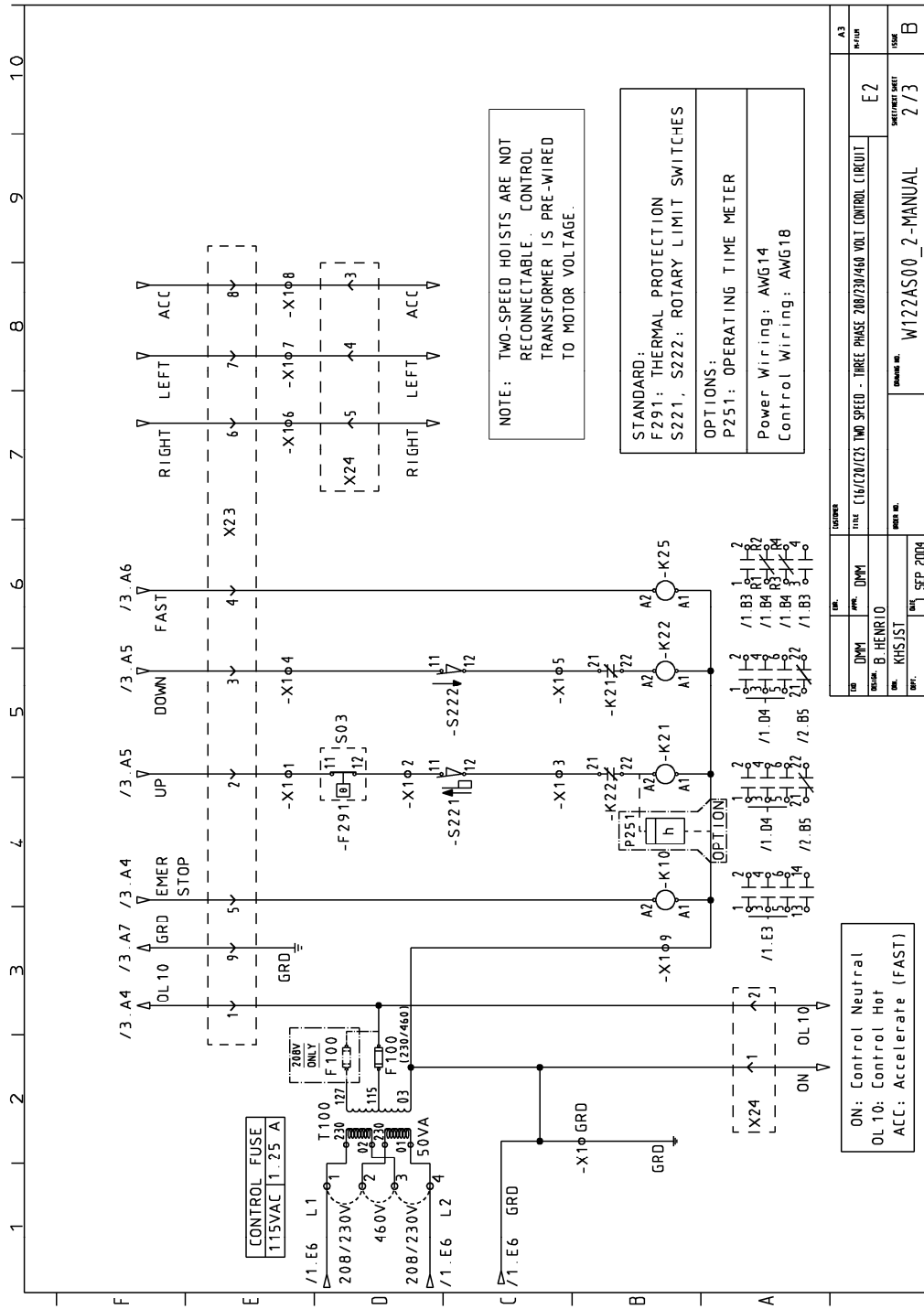



### 5.20 Two Speed – Three Phase – 575 Volt – Power Circuit

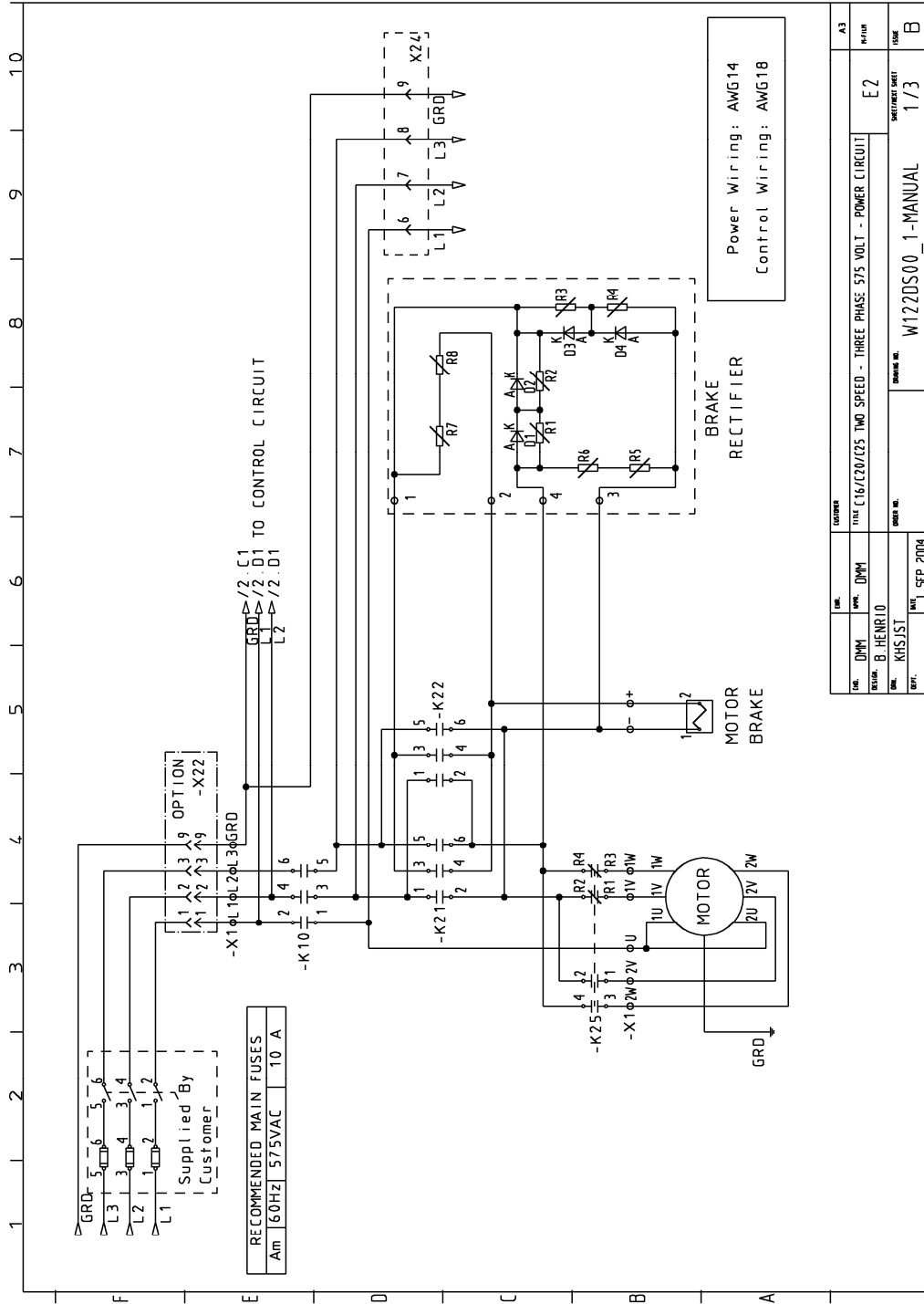

REV.	DATE	BY	CHKD.	DESCRIPTION
01	01/01/01	B. HENRIU		FILE C16/C20/C25 TWO SPEED - THREE PHASE 575 VOLT - POWER CIRCUIT
02	01/01/01	KHSJST		
03	01/01/01			
04	01/01/01			
05	01/01/01			
06	01/01/01			
07	01/01/01			
08	01/01/01			
09	01/01/01			
10	01/01/01			
11	01/01/01			
12	01/01/01			
13	01/01/01			
14	01/01/01			
15	01/01/01			
16	01/01/01			
17	01/01/01			
18	01/01/01			
19	01/01/01			
20	01/01/01			
21	01/01/01			
22	01/01/01			
23	01/01/01			
24	01/01/01			
25	01/01/01			
26	01/01/01			
27	01/01/01			
28	01/01/01			
29	01/01/01			
30	01/01/01			
31	01/01/01			
32	01/01/01			
33	01/01/01			
34	01/01/01			
35	01/01/01			
36	01/01/01			
37	01/01/01			
38	01/01/01			
39	01/01/01			
40	01/01/01			
41	01/01/01			
42	01/01/01			
43	01/01/01			
44	01/01/01			
45	01/01/01			
46	01/01/01			
47	01/01/01			
48	01/01/01			
49	01/01/01			
50	01/01/01			
51	01/01/01			
52	01/01/01			
53	01/01/01			
54	01/01/01			
55	01/01/01			
56	01/01/01			
57	01/01/01			
58	01/01/01			
59	01/01/01			
60	01/01/01			
61	01/01/01			
62	01/01/01			
63	01/01/01			
64	01/01/01			
65	01/01/01			
66	01/01/01			
67	01/01/01			
68	01/01/01			
69	01/01/01			
70	01/01/01			
71	01/01/01			
72	01/01/01			
73	01/01/01			
74	01/01/01			
75	01/01/01			
76	01/01/01			
77	01/01/01			
78	01/01/01			
79	01/01/01			
80	01/01/01			
81	01/01/01			
82	01/01/01			
83	01/01/01			
84	01/01/01			
85	01/01/01			
86	01/01/01			
87	01/01/01			
88	01/01/01			
89	01/01/01			
90	01/01/01			
91	01/01/01			
92	01/01/01			
93	01/01/01			
94	01/01/01			
95	01/01/01			
96	01/01/01			
97	01/01/01			
98	01/01/01			
99	01/01/01			
100	01/01/01			

### 5.21 Two Speed – Three Phase – 575 Volt – Control Circuit

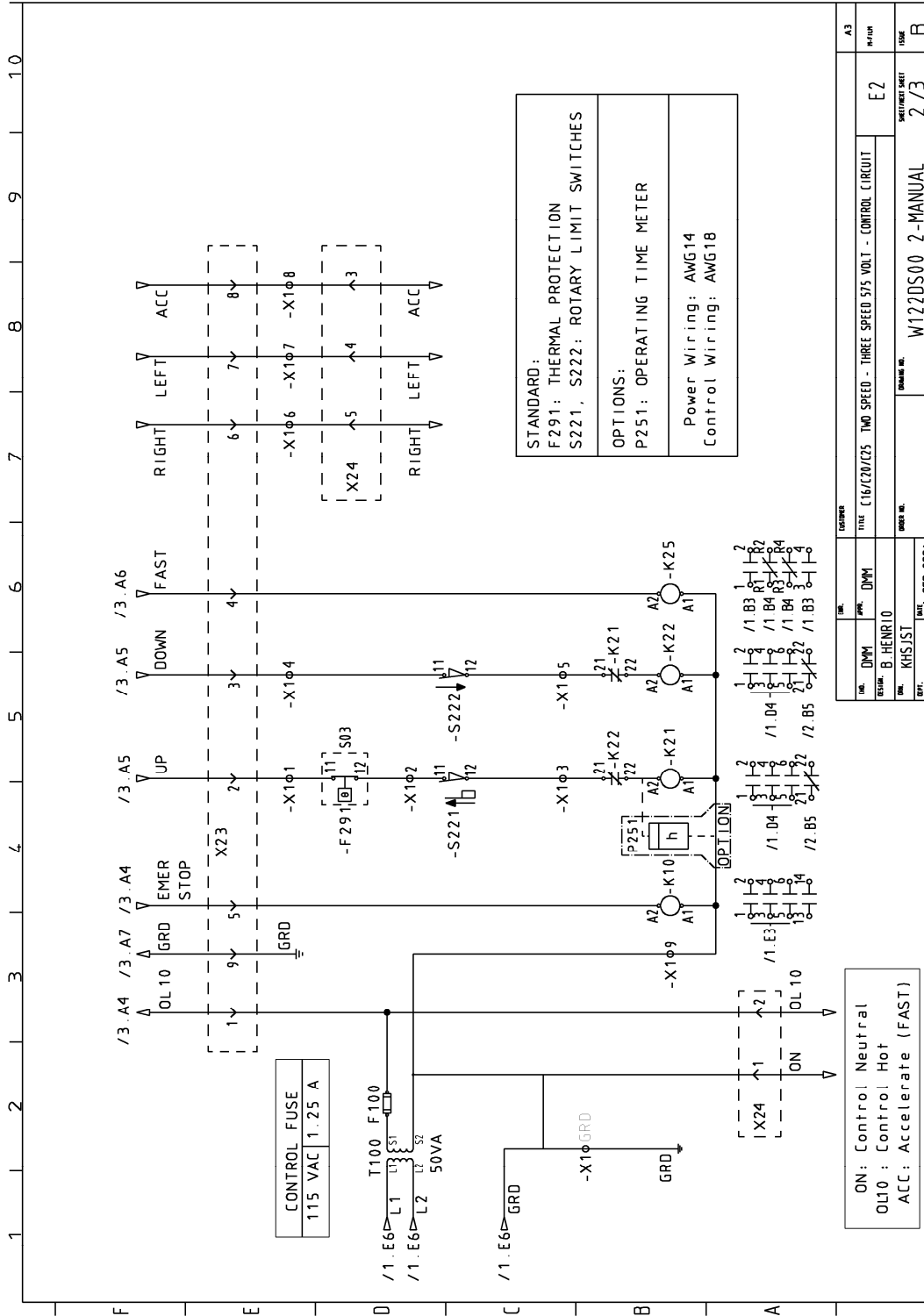

### 5.22 Wiring Diagram – 3 Button – Push Button

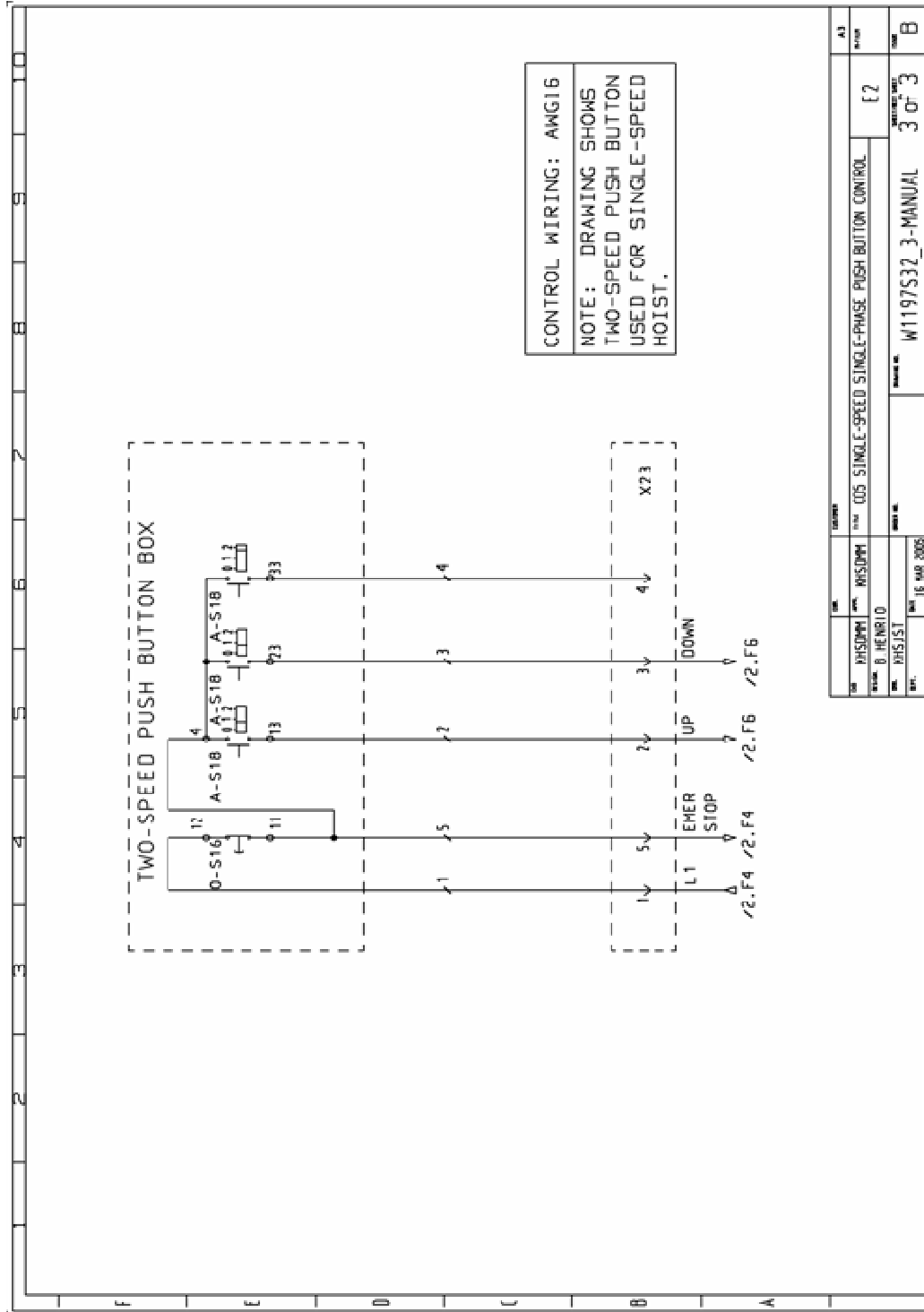

## 5.23 Wiring Diagram – 5 Button – Push Button

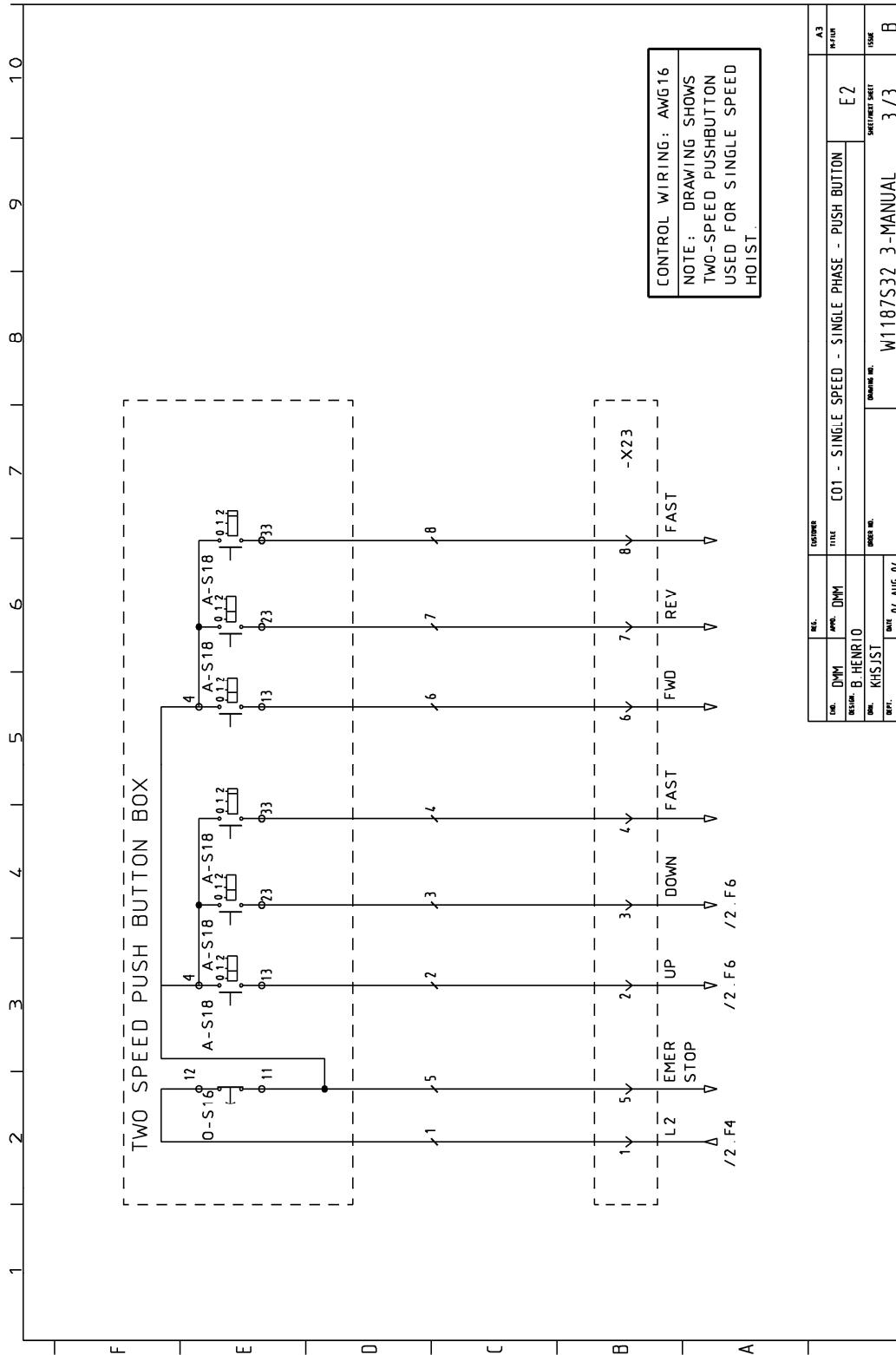

### 5.24 Wiring Diagram – 7 Button – Push Button

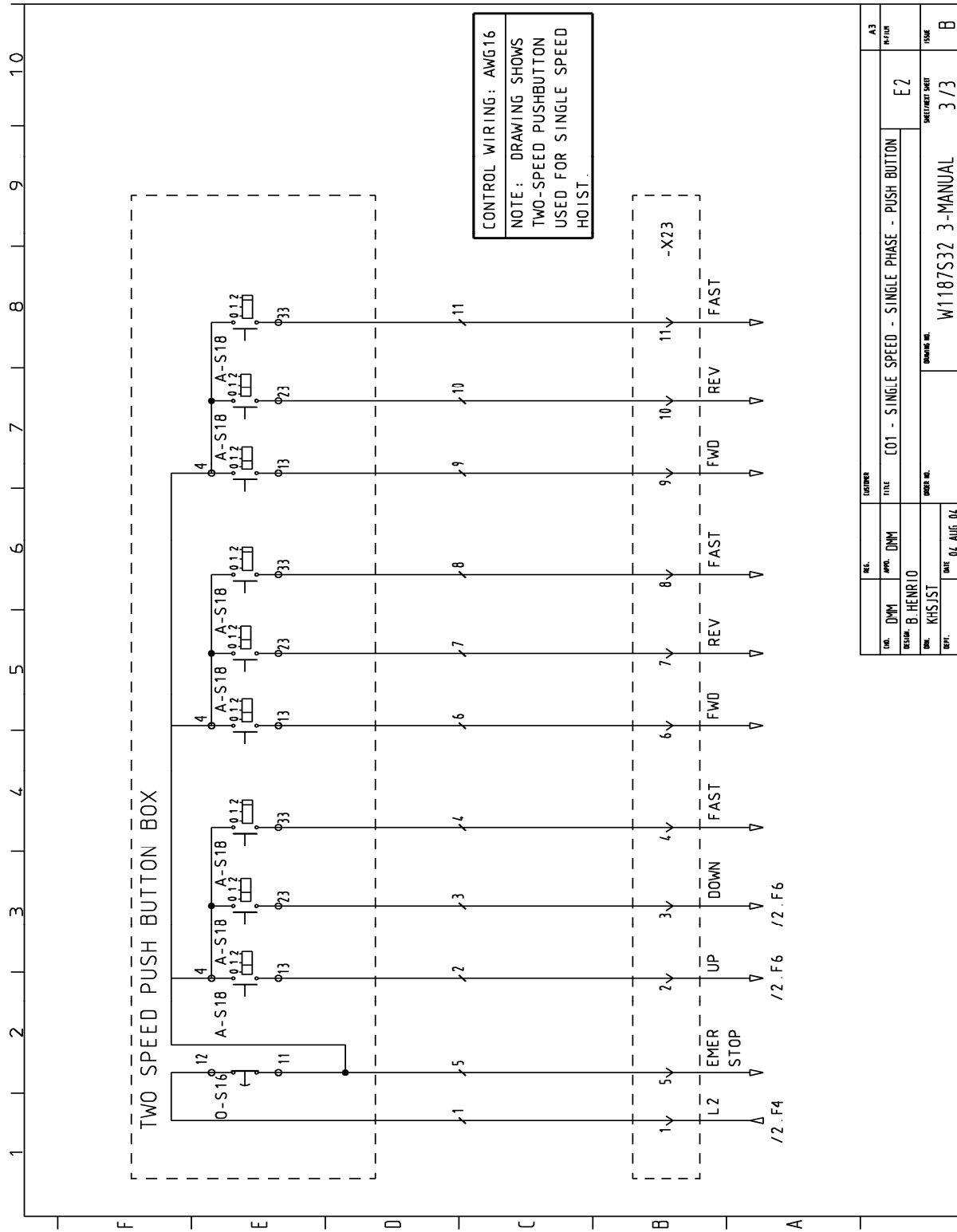

## 6 PREVENTATIVE MAINTENANCE

### 6.1 Maintenance and Inspection Table

Table 6. Maintenance Schedule

INSPECTION CHECK	INTERVAL	QUALIFIED PERSON
BRAKE OPERATION FOR HOLDING AND RELEASING	DAILY	OPERATOR
LOAD CHAIN FOR DAMAGE	DAILY	OPERATOR
SUSPENSION SUPPORT OF P/ B ASSEMBLY	DAILY	OPERATOR
CLEANLINESS & LUBRICATION OF LOAD CHAIN	MONTHLY	OPERATOR
UPPER / LOWER LIMIT SWITCHES	DAILY	OPERATOR
CHECK LOAD CHAIN FOR WEAR – MEASURE AND RECORD	EVERY 3 MONTHS	QUALIFIED INSPECTOR
CHECK HOOKS FOR WEAR MEASURE AND RECORD	EVERY 3 MONTHS	QUALIFIED INSPECTOR
CHECK LOAD BLOCK HARDWARE TO VERIFY TIGHTNESS	EVERY 3 MONTHS	OPERATOR
CHECK TOP HOOK / COUPLING HARDWARE FOR TIGHTNESS	EVERY 3 MONTHS	OPERATOR
CHECK SLIP CLUTCH & HOIST BRAKE ADJUSTMENT	EVERY 3 -6 MONTHS	QUALIFIED MECHANIC
CHECK LUBRICATION OF OPEN WHEEL GEARING	EVERY 3 -6 MONTHS	QUALIFIED MECHANIC
CHECK WIRE TERMINALS TIGHTNESS	SEMI-ANNUALLY	QUALIFIED MECHANIC
LUBRICATE 2-FALL LOAD BLOCK SPROCKET	ANNUALLY	OPERATOR
CHECK ALL HARDWARE FOR TIGHTNESS AND CORROSION	ANNUALLY	QUALIFIED MECHANIC
CLEAN MOTOR COOLING FINS	ANNUALLY	QUALIFIED MECHANIC
LUBRICATE ALL GEARING	ANNUALLY	QUALIFIED MECHANIC
INSPECT LOAD BLOCK THRUST BEARING	ANNUALLY	QUALIFIED MECHANIC

**⚠ CAUTION: INSPECTION AND MAINTENANCE INTERVALS SHOULD BE ADJUSTED BASED UPON OWNER / USER KNOWLEDGE OF APPLICATION, ENVIRONMENT, AND FREQUENCY OF USE TO PREVENT DAMAGE TO PEOPLE, EQUIPMENT, AND FACILITIES.**

## 6.2 Lubrication

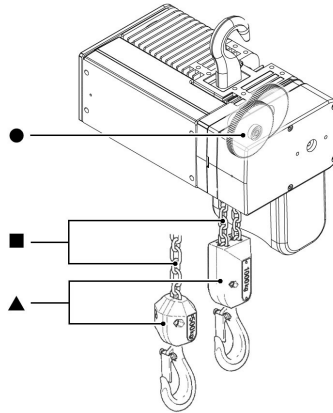

Table 7. Lubrication Specifications

LUBRICATION POINT	SPECIFICATIONS	ACCEPTABLE LUBRICANTS	QUANTITY
<b>Chain</b> ■	Oil or Liquid grease	Chain lubricating fluid (Ceplattyn or similar) EP-90	As required
<b>Idler sprocket Slide bearing + bearing</b> ▲	Grease (without MoS2) KP 2 (DIN 51 502) Soap-based lithium Approx. drip point + 500 °F Worked penetration 509-563 °F Operating temperature - 4 °F - +266 °F	BP: BP Energrease LS - EP 2 Esso: Unirex N2 Mobil: Mobilgrease HP Shell: Shell Alvania EP Grease 2	As required
<b>Gears</b> ●	Oil EP220	Mobil: L-CKC220 BP: Energol XP220 Shell: Omala 150/220	1.6 liters 1 ¾ qts

**Open Wheel Gearing: EP1 Mobilux or equivalent.**

### 6.3 Recommended Technical Support for Various Spare Parts

Table 8. Recommended Technical Support for Various Spare Parts

SPARE PART	REPLACED BY
Upper chain guide	Qualified Electrician & Mechanic
Output shaft	Qualified Electrician & Mechanic
PG cable gland	Qualified Electrician
Gear input shaft + adjusting nuts	Qualified Mechanic
Motor end cap	Qualified Mechanic
Gearing (1st/2nd stage)	Qualified Electrician & Mechanic
Brake & end cap sealing	Qualified Mechanic
Other seals and O-rings	Qualified Mechanic
Brake-limiter	Qualified Electrician
Brake end cap	Qualified Mechanic
Lower chain guide	Qualified Mechanic
Rubber buffer	Qualified Mechanic
Electric box	Qualified Electrician
PC-board	Qualified Electrician
Plugs	Qualified Electrician
Chain	Qualified Mechanic
Chain bucket	Qualified Mechanic
Slack fall stop	Qualified Mechanic
Suspension hook	Qualified Mechanic
Hook block (1/1; 2/1)	Qualified Mechanic
Control box	Qualified Electrician



Once a part has been replaced, perform an operational check of hoist per Sections 3.3 and 3.4.

### 6.4 Screw Tightening Torque (lb-ft) Specifications

Table 9. Screw Tightening Torque (lb-ft) Specifications

TYPE	M5	M6	M8	M10	M12
STANDARD SCREWS	4	7	18	35	61
SELF-TAPING SCREWS	4	6	15	30	53



## 6.5 Troubleshooting

Table 10. Troubleshooting

PROBLEM	POSSIBLE CAUSE	POSSIBLE SOLUTION
Hoist does not lift or lower load	Emergency stop button is activated	Deactivate button
	Blown fuse	Replace the fuse
	Motor thermal protection activated	Allow motor to cool down
	Pendant plug pin pushed out	Reinstall plug pin
	Contactors terminal screws loose	Tighten screws
	Mainline switch shut off	Turn switch on
Hoist does not lift load	Overload condition	Reduce load
	Slip clutch worn or incorrectly adjusted	Replace wear items or readjust slip clutch torque
	Brake not releasing	Check brake coil resistance. Check air gap setting. Adjust if necessary. Check rectifier output voltage.
Load drifts more than 4 inches [100mm]	Brake lining worn Air gap on brake is too wide	Replace wear items as necessary Adjust air gap setting
Travel direction does not correspond to that indicated on push button	Power supply incorrectly connected	See SECTION 2
Abnormal noises while lifting or lowering	Load chain and its components are not lubricated	Clean and lubricate load chain.
	Load chain is worn	Replace chain
	Chain wheel or chain guide is worn	Replace chain wheel or chain guide
	Idler sprocket is worn	Replace idler sprocket
	A supply phase is missing	Connect the three phases
	Twist or kink in load chain	Remove twist or kink

## 7 PARTS ILLUSTRATIONS

### 7.1 Hoist Gearbox Components

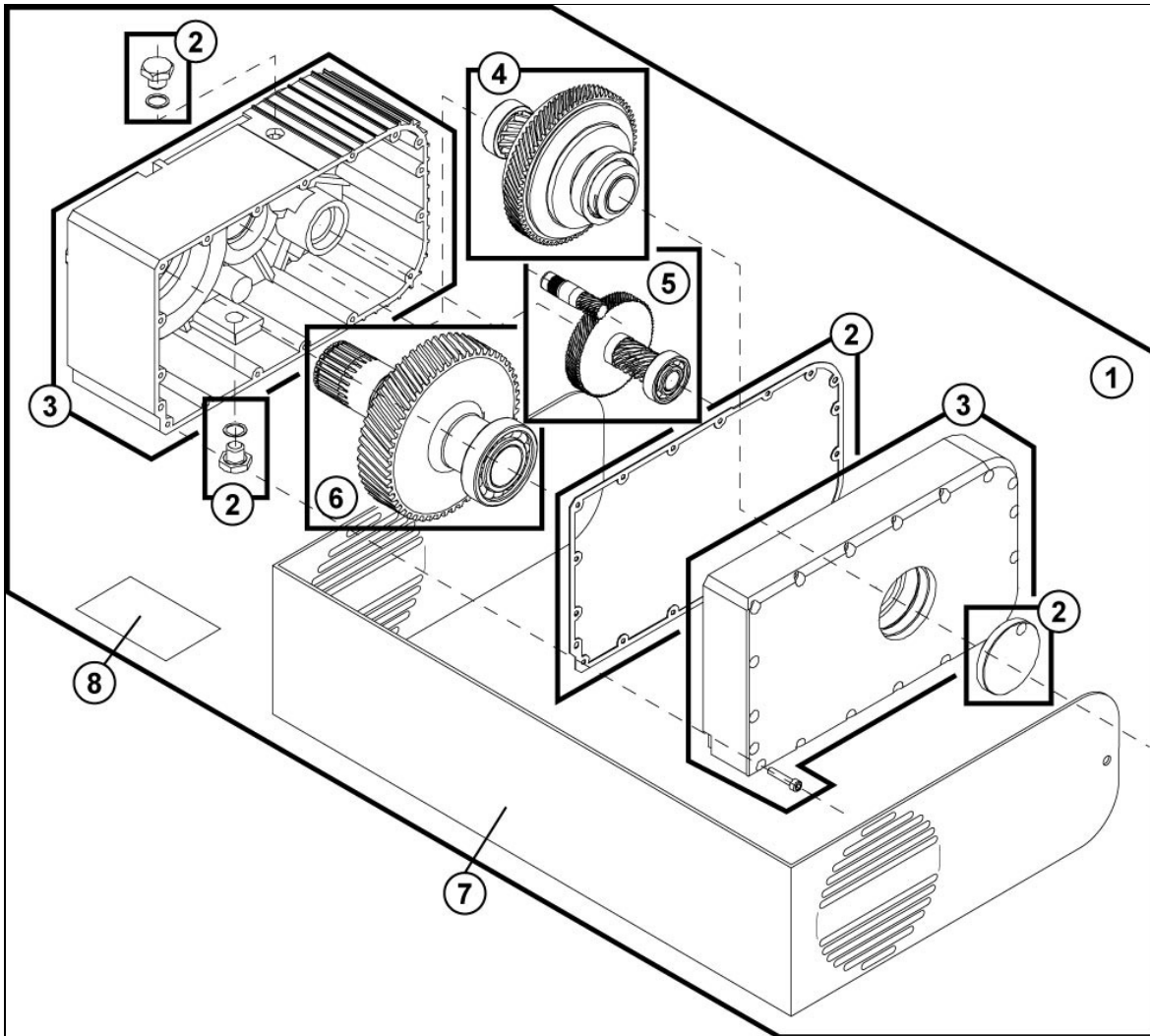

Table 11. Hoist Gearbox Parts List

ITEM	PART NUMBER	DESCRIPTION	QTY
	2269955	C16 BODY ( TS ) 200-230V 1+3+4	1
	2269956	C16 BODY ( TS ) 460V 1+3+4	1
	2269957	C16 BODY ( TS ) 575V 1+3+4	1
	2279965	C20 BODY ( TS ) 200-230V 1+3+4	1
	2279966	C20 BODY ( TS ) 460V 1+3+4	1
	2279967	C20 BODY ( TS ) 575V 1+3+4	1
	2279968	C25 BODY ( TS ) 200-230V 1+3+4	1
	2279969	C25 BODY ( TS ) 460V 1+3+4	1
	2269955	C16 BODY ( TS ) 200-230V 1+3+4	1
1	2260500	C16/20 GEARBOX ASSEMBLY – 113:1 – 32 / 8 FPM	1
1	2270500	C25 GEARBOX ASSEMBLY – 144.2:1 – 24 / 6 FPM	1
2	2279923	SEAL SET	1
3	2270000	GEAR CASE HOUSING	1
4	2279904	GEAR SET – 2 <sup>nd</sup> REDUCTION	1
5a	2279902	GEAR SET – 1 <sup>st</sup> REDUCTION – C16/20	1
5b	2279903	GEAR SET – 1 <sup>st</sup> REDUCTION – C25	1
6	2279905	GEAR SET – 3 <sup>rd</sup> REDUCTION	1
7	<a href="#">52340377</a>	<a href="#">XN BRANDING BAND</a>	1
8	2213309002	HOIST BODY CAPACITY STICKER – ½ TON	1
8	2213309003	HOIST BODY CAPACITY STICKER – 1 TON	1
8	2213309004	HOIST BODY CAPACITY STICKER – 2.0 TON	1
8	2213309008	HOIST BODY CAPACITY STICKER – 500 KG	1
8	2213309009	HOIST BODY CAPACITY STICKER – 1000 KG	1
8	2213309010	HOIST BODY CAPACITY STICKER – 2000 KG	1
8	2213309011	HOIST BODY CAPACITY STICKER – 3200 KG	1
8	2213309012	HOIST BODY CAPACITY STICKER – 5000 KG	1
8	2213309013	HOIST BODY CAPACITY STICKER – 5.0 TON	1
8	2213309014	HOIST BODY CAPACITY STICKER – 1.5 TON	1
8	2213309015	HOIST BODY CAPACITY STICKER – 2.5 TON	1
8	2213309016	HOIST BODY CAPACITY STICKER – 1500 KG	1
8	2213309017	HOIST BODY CAPACITY STICKER – 2500 KG	1
8	2213309019	HOIST BODY CAPACITY STICKER – 4000 KG	1
-	2213445001	ELECTRICAL WIRING INFORMATION STICKER	1
-	2213445002	ELECTRICAL HAZARD WARNING STICKER	1

## 7.2 C16 / C20 / C25 Hoist Motor & Brake Assembly

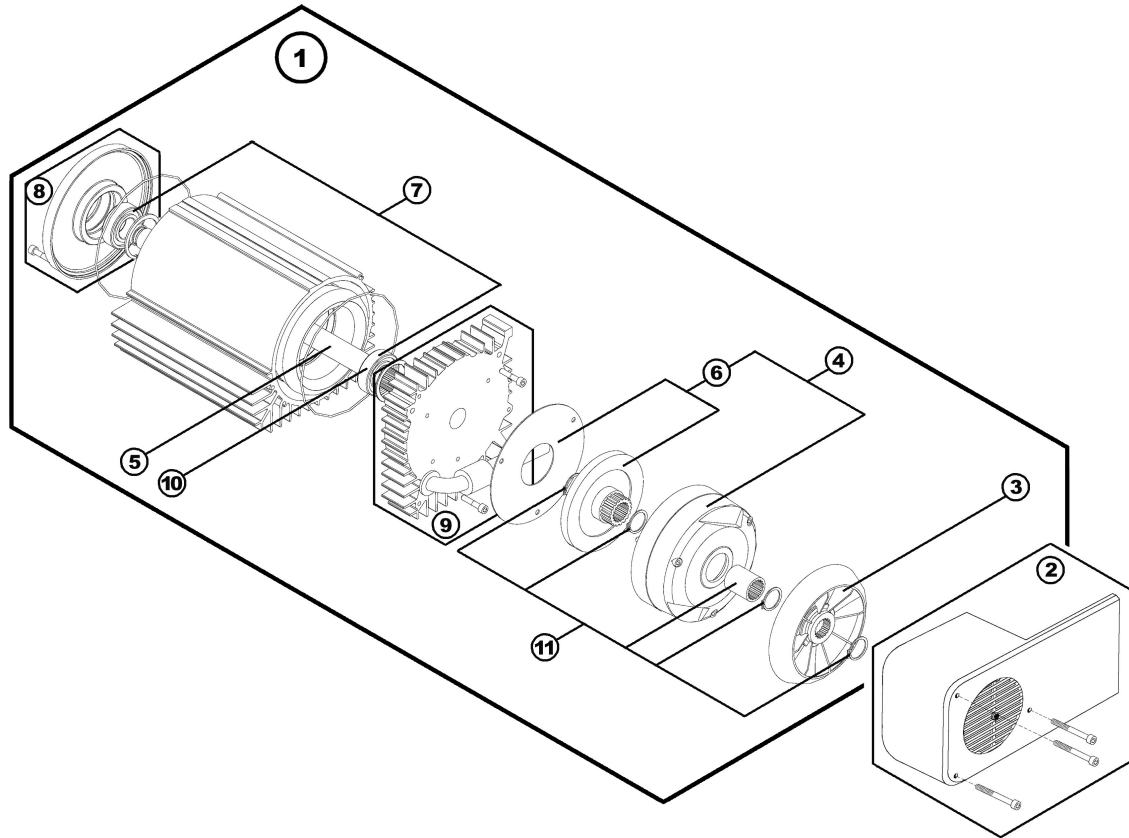

Table 12. C16/C20/C25 Hoist Motor and Brake Assembly Parts List

ITEM	PART NUMBER	DESCRIPTION	QTY
1a	2245033	C16 / C20 MOTOR & BRAKE ASSY with PINION 208/230V	1
1b	2245031	C16 / C20 MOTOR & BRAKE ASSY with PINION 460V	1
1c	2245032	C16 / C20 MOTOR & BRAKE ASSY with PINION 575V	1
1d	2245038	C25 MOTOR & BRAKE ASSY with PINION 208/230V	1
1e	2245036	C25 MOTOR & BRAKE ASSY with PINION 460V	1
1f	2245037	C25 MOTOR & BRAKE ASSY with PINION 575V	1
2	2279901	BRAKE COVER END CAP & SCREW SET	1
3	2275040	FAN ASSEMBLY	1
4a	2275045	MOTOR BRAKE ASSY 100VDC - 208/230VAC	1
4b	2275042	MOTOR BRAKE ASSY 180VDC - 460VAC	1
4c	2275043	MOTOR BRAKE ASSY 240VDC - 575VAC	1
5a	2275051	ROTOR ASSEMBLY – TWO SPEED MOTOR	1
6	2275041	BRAKE DISC ASSEMBLY	1
7a	2275049	BEARING SET – TWO SPEED MOTOR	1
8	2275046	MOTOR END FLANGE – GEARBOX SIDE	1
9	2275047	MOTOR END FLANGE – BRAKE SIDE	1
11	2275053	RETAINING RING AND SPLINED TUBE ASSEMBLY	1

### 7.3 Lifting Assembly – C16 Only

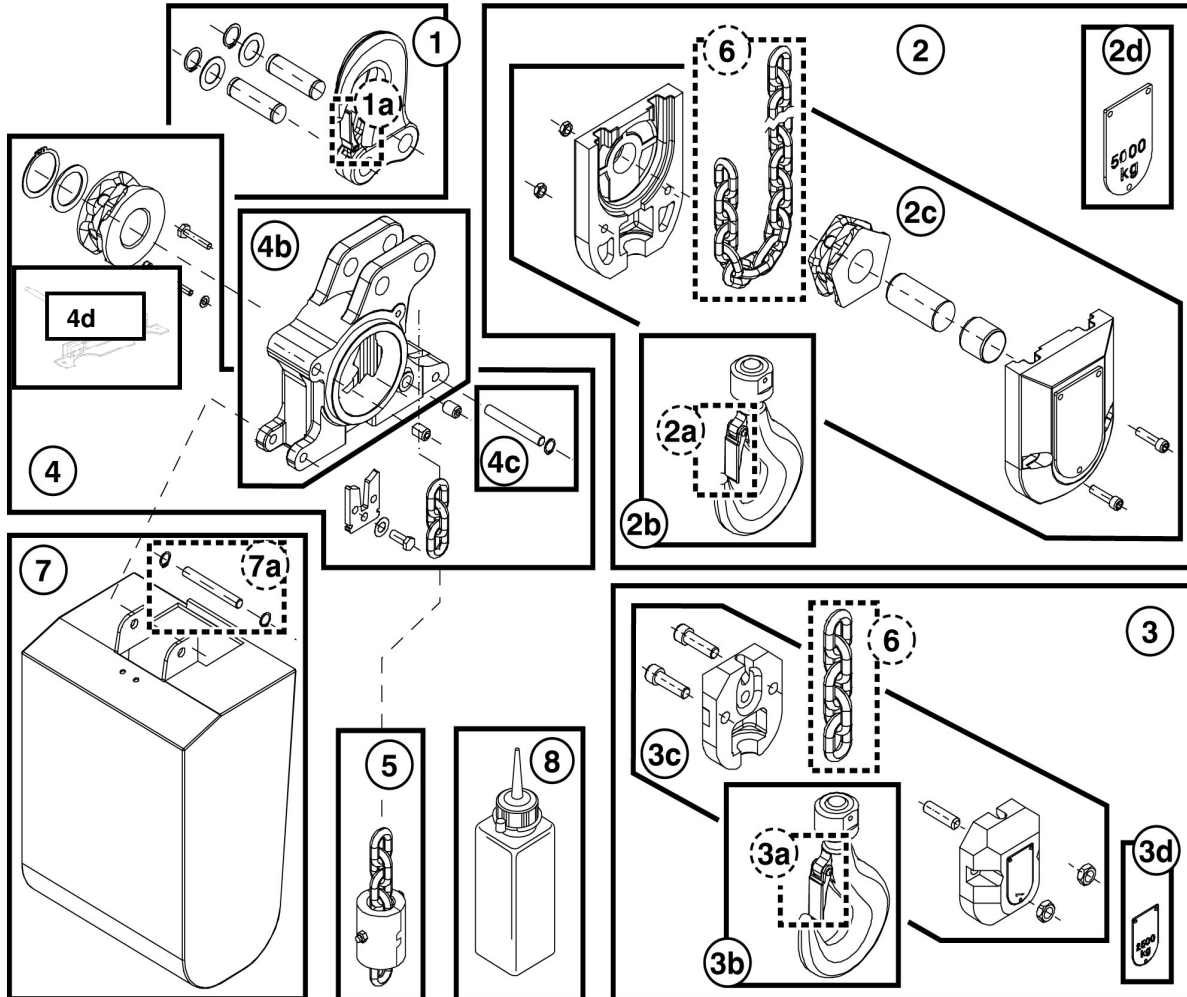

Table 13. C16 Lifting Assembly Parts List - (C16 ONLY)

ITEM	PART NUMBER	DESCRIPTION	QTY
1	2279955	TOP HOOK SET ( includes 2+3+4+5+6 )	1
1a	2279914	TOP HOOK SAFETY LATCH – STEEL PLATE TYPE	1
2	2269915	C16 HOOK BLOCK ASSEMBLY 2-FALL	1
2a	2279914	C16 HOOK SAFETY LATCH 2-FALL STEEL PLATE TYPE	1
2b	2267000	C16 HOOK ASSEMBLY 2-FALL	1
2d	2213405003	CAPACITY STICKER – 2 TON 2-FALL	2
2d	2213405004	CAPACITY STICKER – 3 TON 2-FALL	2
2d	2213405010	CAPACITY STICKER – 2000 KG 2-FALL	2
2d	2213405011	CAPACITY STICKER – 3000 KG 2-FALL	2
3	2269900	C16 HOOK BLOCK ASSEMBLY 1-FALL	1
3a	001513	C16 HOOK SAFETY LATCH 1-FALL – WIRE TYPE	1
3b	2242021	C16 HOOK ASSEMBLY 1-FALL	1
3d	2213405001	CAPACITY STICKER – 1 TON 1-FALL	2
3d	2213405002	CAPACITY STICKER – 1.5 TON 1-FALL	2
3d	2213405008	CAPACITY STICKER – 1000 KG 1-FALL	2
3d	2213405009	CAPACITY STICKER – 1500 KG 1-FALL	2
4	2269913	C16 CHAIN SPROCKET SET	1
4b	2265502	C16 CHAIN GUIDE	1
4c	2269914	DEAD END PIN 9 X 27 CHAIN	1
4d	52332038	LIMIT SWITCH ASSEMBLY	1
5	2269942	C16 SLACK FALL STOP	1
6a	2263500	C16 LOAD CHAIN – ZINC PLATED (STANDARD)	*
6b	2263502	C16 LOAD CHAIN – STAINLESS STEEL – CHECK CAPACITY	*
7	2279912	CHAIN BUCKET PIN KIT	1
7a	2279930	CHAIN CONTAINER & MTG PIN SET - 50ft C16 / 40ft C20/25	1
7b	2279931	CHAIN CONTAINER & MTG PIN SET – 150ft C16 / 100ft C20/25	1
7c	2279932	CHAIN CONTAINER & MTG PIN SET – 150ft C20/25	1
8	9995008	CHAIN LUBE	1



**\* NOTE: REFER TO CHAIN HOIST LIFT AND NUMBER OF FALLS FOR CHAIN QUANTITY**

### 7.4 Lifting Assembly – C20/25 Only

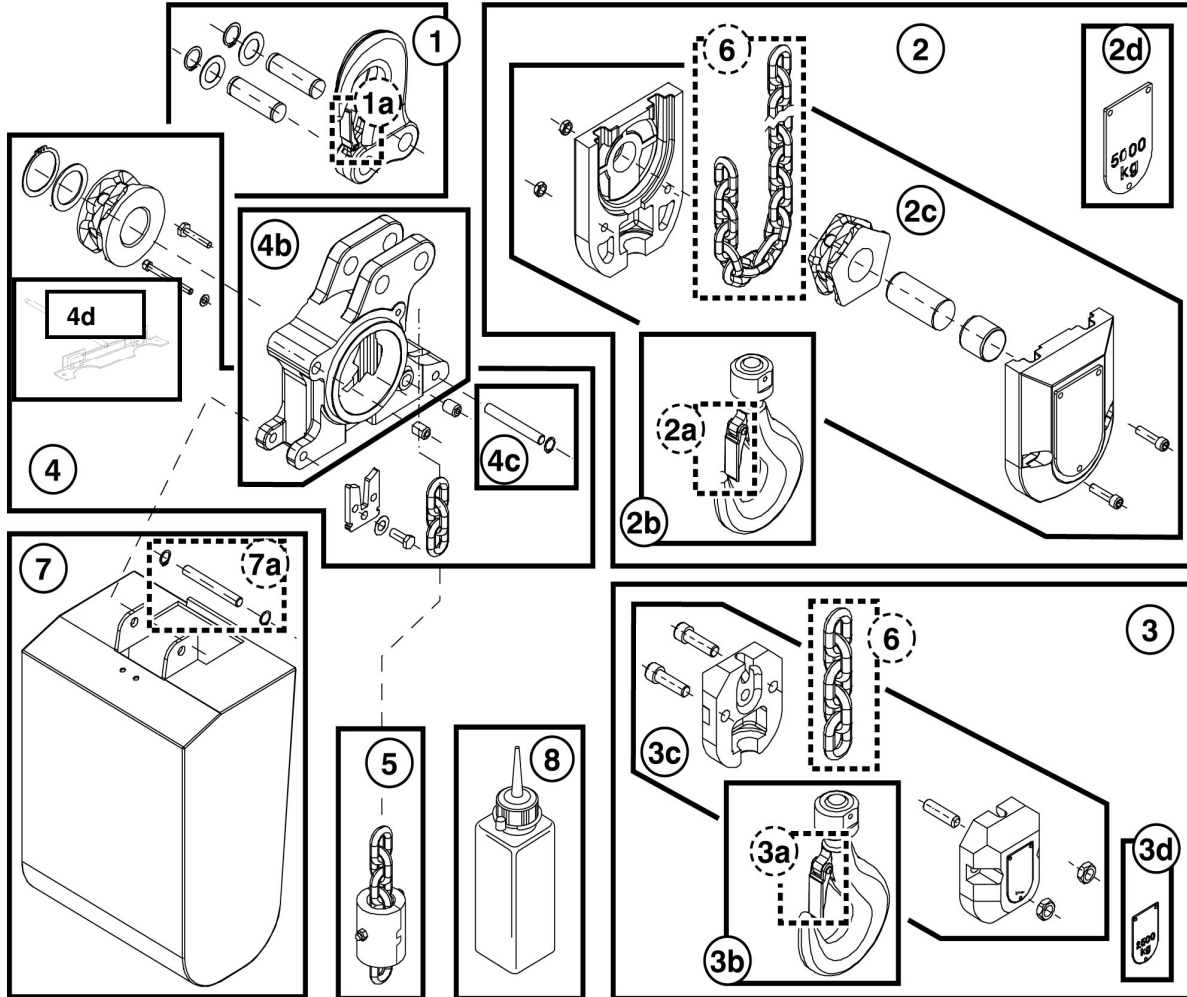



Table 14. C20 / C25 Lifting Assembly Parts List - (C20 / C25 ONLY)

ITEM	PART NUMBER	DESCRIPTION	QTY
1	2279955	TOP HOOK SET (includes 2+3+4+5+6)	1
1a	2279914	TOP HOOK SAFETY LATCH – STEEL PLATE TYPE	1
2	2279915	C20/25 HOOK BLOCK ASSEMBLY 2-FALL	1
2a	2279914	C20/25 HOOK SAFETY LATCH 2-FALL STEEL PLATE TYPE	1
2b	2277001	C20/25 HOOK ASSEMBLY 2-FALL	1
2d	2213406002	CAPACITY STICKER – 3 TON 2-FALL	2
2d	2213406005	CAPACITY STICKER – 4 TON 2-FALL	2
2d	2213406003	CAPACITY STICKER – 5 TON 2-FALL	2
2d	2213406009	CAPACITY STICKER – 3000 KG 2-FALL	2
2d	2213406013	CAPACITY STICKER – 4000 KG 2-FALL	2
2d	2213406010	CAPACITY STICKER – 5000 KG 2-FALL	2
3	2279900	C20/25 HOOK BLOCK ASSEMBLY 1-FALL	1
3a	2242017	C20/25 HOOK SAFETY LATCH 1-FALL – WIRE TYPE	1
3b	2277000	C20/25 HOOK ASSEMBLY 1-FALL	1
3d	2213405002	CAPACITY STICKER – 1.5 TON 1-FALL	2
3d	2213405003	CAPACITY STICKER – 2.0 TON 1-FALL	2
3d	2213405004	CAPACITY STICKER – 3.0 TON 1-FALL	2
3d	2213405009	CAPACITY STICKER – 1500 KG 1-FALL	2
3d	2213405010	CAPACITY STICKER – 2000 KG 1-FALL	2
3d	2213405007	CAPACITY STICKER – 3000 KG 1-FALL	2
4	2279911	C20/25 CHAIN SPROCKET SET	1
4b	2275502	C20/25 CHAIN GUIDE	1
4c	2279910	DEAD END PIN 11.3 X 31 CHAIN	1
4d	52332038	LIMIT SWITCH ASSEMBLY	1
5	2279942	C20/25 SLACK FALL STOP	1
6a	2273500	C20/25 LOAD CHAIN – ZINC PLATED (STANDARD)	*
6b	2273502	C20/25 LOAD CHAIN – STAINLESS STEEL – CHECK CAPACITY	*
7	2279912	CHAIN BUCKET PIN KIT	1
7a	2279930	CHAIN CONTAINER & MTG PIN SET – 50ft C16 / 40ft C20/25	1
7b	2279931	CHAIN CONTAINER & MTG PIN SET – 150ft C16 / 100ft C20/25	1
7c	2279932	CHAIN CONTAINER & MTG PIN SET – 150ft C20/25	1
8	9995008	CHAIN LUBE	1



**\* NOTE: REFER TO CHAIN HOIST LIFT AND NUMBER OF FALLS FOR CHAIN QUANTITY**

## 7.5 C16 / C20 / C25 Electrical Control Assembly

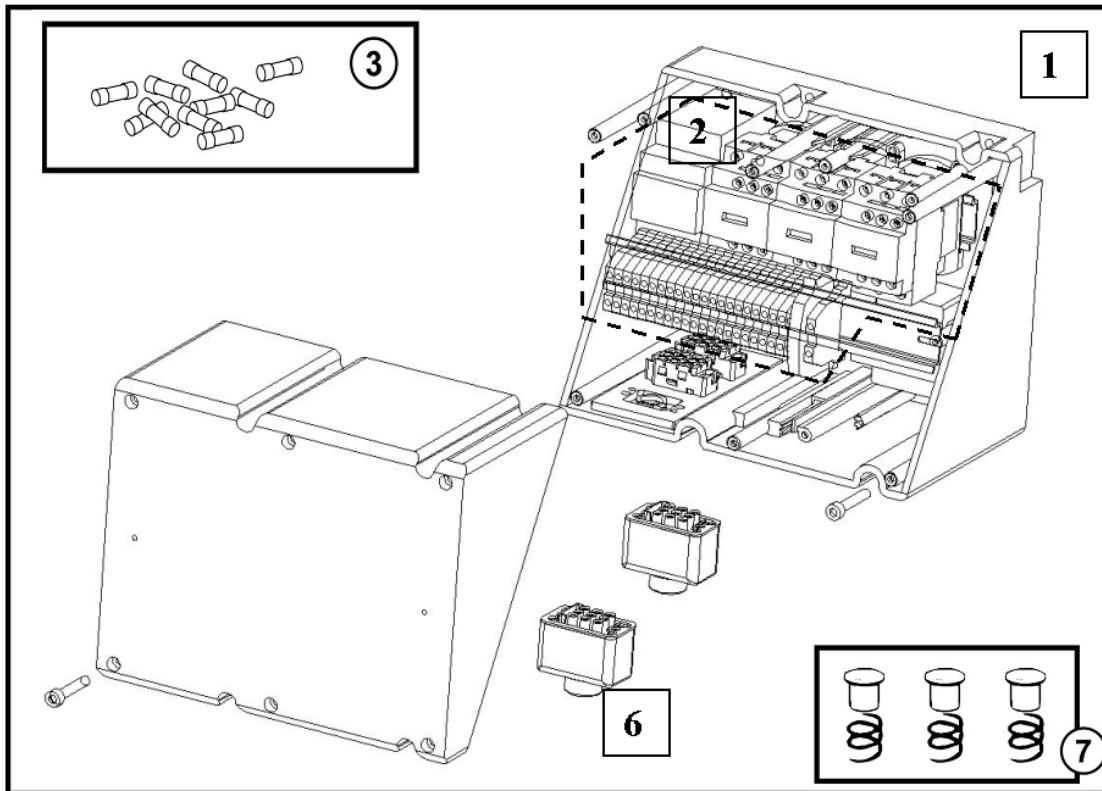

Table 15. C16/C20/C25 Electrical Control Assembly Parts List

ITEM	PART NUMBER	DESCRIPTION	QTY
1	2263015	CONTROL BOX (BASE + COVER)	1
2	2263006	CONTROL PANEL ASSEMBLY: 208/230/460V – 115V – 60HZ	1
2	2263007	CONTROL PANEL ASSEMBLY: 575V – 115V – 60HZ	1
2a	2309564003	CONTACTOR K10 - 208/230/460/575V – 115V CONT	1
2b	2309564006	CONTACTOR K21 or K22 - 208/230/460/575V – 115V CONT	1
2c	2309568004	CONTACTOR K25 - 208/230/460/575V – 115V CONT	1
2d	7983026	TRANSFORMER - 208/230/460V - 115V	1
2d	7983027	TRANSFORMER - 575V - 115V	1
2e	2243060	BRAKE RECTIFIER 4 – WIRES 208 - 575VAC	1
2e	2243061	BRAKE RECTIFIER 5 – WIRES 208 - 460VAC (RECONNECT)	1
3	2249979	1.25 AMP FUSES – SET OF 10	1
4	2249947	POWER CABLE GLAND – NOT SHOWN	1
5	2219814	COVER PLATE – USED WHEN PLUG IS REMOVED – NOT SHOWN	1
6	2249946	PLUG FOR TROLLEY CIRCUIT	1
6	2249982	POWER PLUG – OPTIONAL	1
6	2249945	PLUG FOR PENDANT	1
7a	2269010	C16 SPRING & WASHER ASSEMBLY – 1 FALL	2
7a	2269010	C16 SPRING & WASHER ASSEMBLY – 2 FALL	3
7b	2279010	C20/25 SPRING & WASHER ASSEMBLY – 1 FALL	2
7b	2279010	C20/25 SPRING & WASHER ASSEMBLY – 2 FALL	3
-	2213445001	ELECTRICAL WIRING INFORMATION STICKER	1
-	2213445002	ELECTRICAL HAZARD WARNING STICKER	1

## 7.6 Double Brake (Option) C16 / C20 / C25

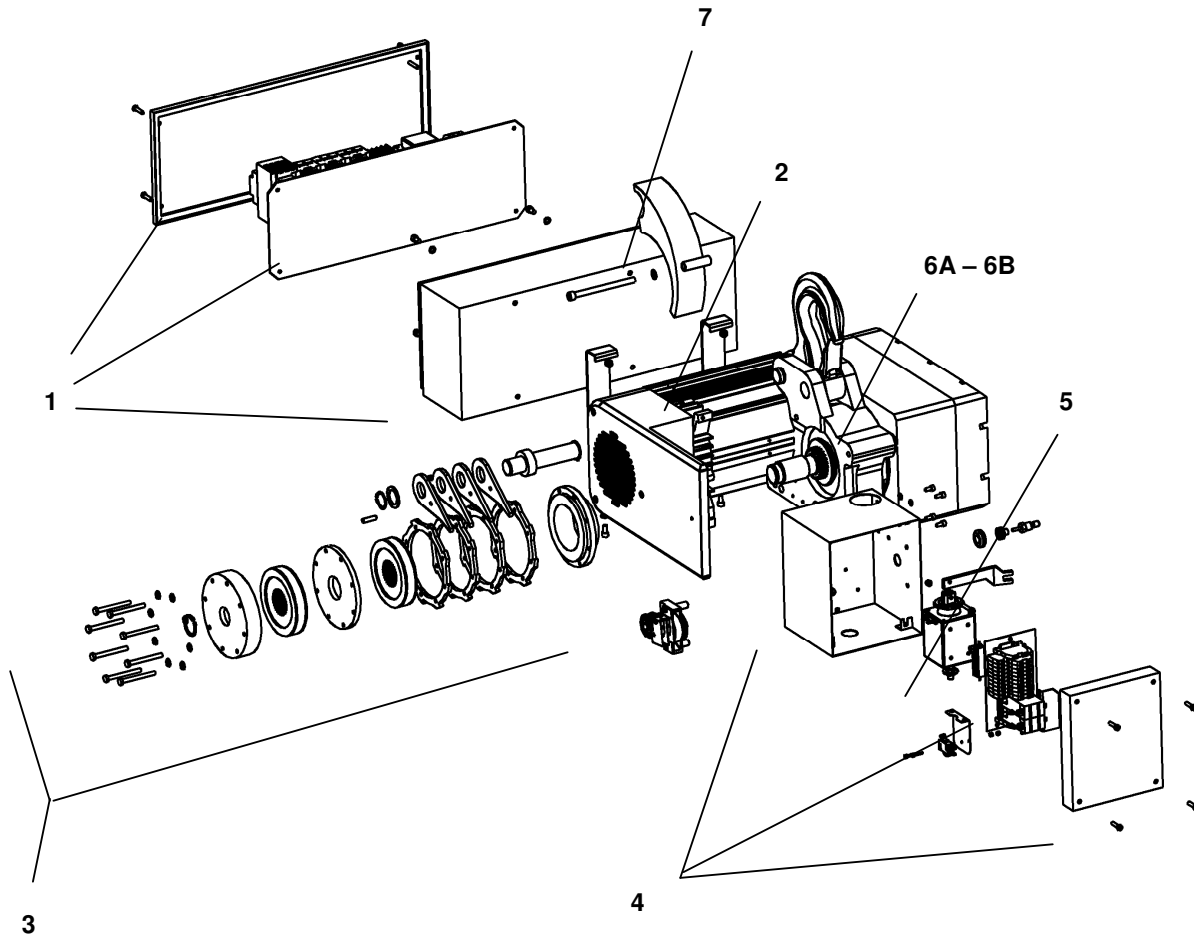

Table 16. C16/C20/C25 Double Brake Option Parts List

ITEM	PART NUMBER	DESCRIPTION	QTY
1	52336943	COMPLETE BOX FOR LOW VOLTAGE	1
2	52338342	SUPPORT BOX ASSY FOR LOW VOLTAGE	1
3	52337007	BRAKE ASSEMBLY	1
4	52336944	COMPLETE MAGNET BOX	1
5	52335461	MAGNET ONLY	1
6A	52337909	GEAR C25 GE25-4 6.3/1.6m/min	1
6B	52337923	GEAR C16 GE25-1 8/2 m/min	
7	52335439	CASING	1

## 7.7 Push Button Assembly – Horizontal Pairs of Buttons

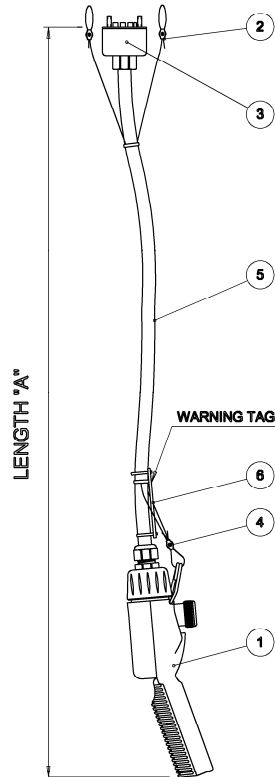

Table 17. Push Button Assembly (Horizontal Pairs of Buttons) Parts List

ITEM	PART NUMBER	DESCRIPTION	QTY
-	2309765010	P/B ASSEMBLY 10 FT, E-STOP, TWO SPEED HOIST	1
-	2309765015	P/B ASSEMBLY 15 FT, E-STOP, TWO SPEED HOIST	1
-	2309765020	P/B ASSEMBLY 20 FT, E-STOP, TWO SPEED HOIST	1
-	2309767010	P/B ASSEMBLY 10 FT, E-STOP, TWO SPEED HOIST, TWO SPEED TROLLEY	1
-	2309767015	P/B ASSEMBLY 15 FT, E-STOP, TWO SPEED HOIST, TWO SPEED TROLLEY	1
-	2309767020	P/B ASSEMBLY 20 FT, E-STOP, TWO SPEED HOIST, TWO SPEED TROLLEY	1
2	2218000	UPPER SUSPENSION KIT	1
3	7285036	P/B ASSEMBLY - PLUG KIT	1
5	52292266	PUSH BUTTON ELECTRICAL CABLE 16 GAUGE / 12 CONDUCTOR RPC	1
6	52301832	P/B ENCLOSURE ASSEMBLY: E-STOP, TH	1
6	2213466004	P/B ENCLOSURE ASSEMBLY: E-STOP, TH, TT	1
6	2309414004	<b>XN</b> OPERATOR'S WARNING TAG - ENGLISH	1

## 7.8 Push Button Assembly – Horizontal Pairs of Buttons

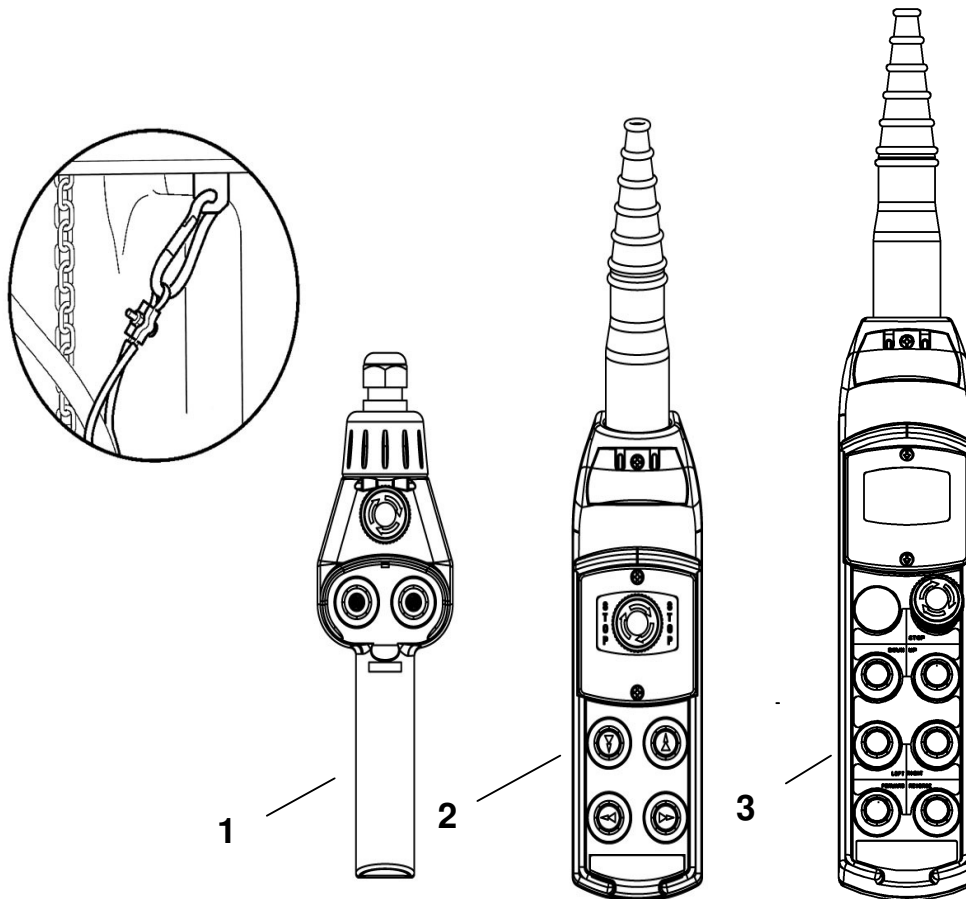

Table 18. Push Button Assembly – Horizontal Pairs of Buttons Parts List

ITEM	PART NUMBER	DESCRIPTION	QTY
1	52301832	PISTOL GRIP P/B CONTROL ASSEMBLY – TWO SPEED	1
2	2213466004	P/B CONTROL ASSEMBLY – TWO SPEED – 5 BUTTON	1
3	2213466005	P/B CONTROL ASSEMBLY – TWO SPEED – 7 BUTTON	1

### 7.9 Push Button Assembly – Vertical Pairs of Buttons (Option)

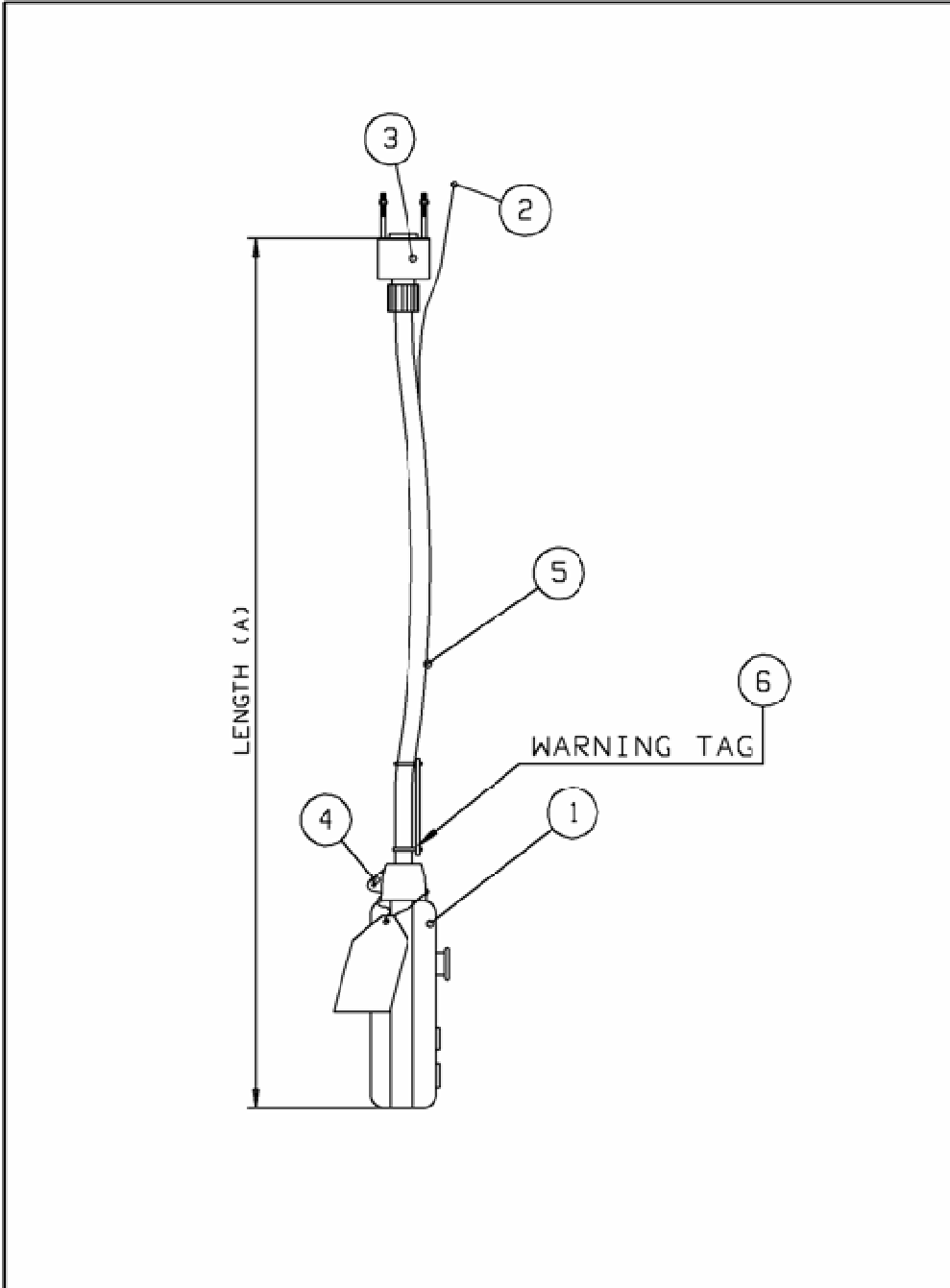

Table 19. Push Button Assembly – Vertical Pairs of Buttons (Option) Parts List

ITEM	PART NUMBER	DESCRIPTION	QTY
-	2309673010	E-STOP, SINGLE SPEED HOIST – 10 FT P/B ASSEMBLY	1
-	2309673015	E-STOP, SINGLE SPEED HOIST – 15 FT P/B ASSEMBLY	1
-	2309673020	E-STOP, SINGLE SPEED HOIST – 20 FT P/B ASSEMBLY	1
-	2309674010	E-STOP, TWO SPEED HOIST – 10 FT P/B ASSEMBLY	1
-	2309674015	E-STOP, TWO SPEED HOIST – 15 FT P/B ASSEMBLY	1
-	2309674020	E-STOP, TWO SPEED HOIST – 20 FT P/B ASSEMBLY	1
1	2212932011	E-STOP, SS HOIST PUSHBUTTON ENCLOSURE ASSEMBLY	1
1	2212932012	E-STOP, TS HOIST PUSHBUTTON ENCLOSURE ASSEMBLY	1
2	2218000	UPPER SUSPENSION KIT	1
3	7285036	PLUG KIT	1
4	558073	SUSPENSION UNIT	1
5	52292266	PUSH BUTTON ELECTRICAL CONTROL CABLE	1
6	2309414004	XN PUSHBUTTON WARNING TAG - ENGLISH	1



## 7.10 Push Button Assembly – Vertical Buttons (Option)

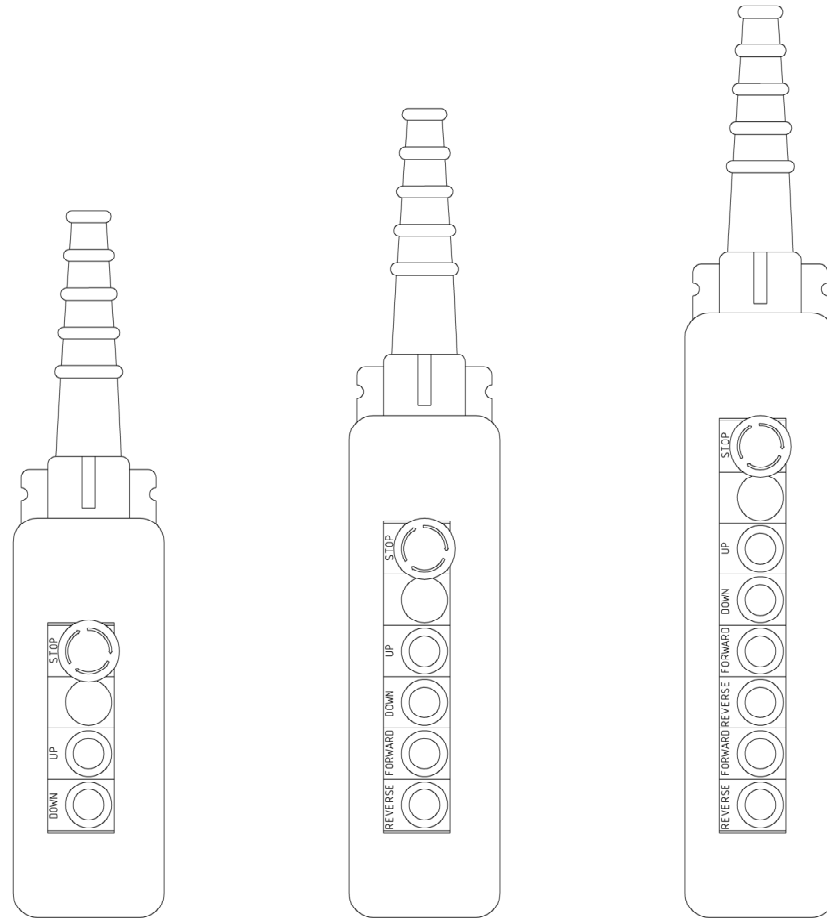

Table 20. Push Button Assembly - Vertical Buttons (Option) Parts List

ITEM	PART NUMBER	DESCRIPTION	QTY
1	2212932011	3 BUTTON P/B TELEMECANIQUE – S*, 1H	1
1	2212932012	3 BUTTON P/B TELEMECANIQUE – S*, 2H	1
2	2212932032	5 BUTTON P/B TELEMECANIQUE – S*, 1H, 2T	1
2	2212932033	5 BUTTON P/B TELEMECANIQUE – S*, 2H, 2T	1
3	2212932034	7 BUTTON P/B TELEMECANIQUE – S*, 2H, 2T, 2B	1
3	2212932035	7 BUTTON P/B TELEMECANIQUE – S*, 1H, 2T, 1B	1
3	2212932036	7 BUTTON P/B TELEMECANIQUE – S*, 2H, 2T, 1B	1
3	2212932037	7 BUTTON P/B TELEMECANIQUE – S*, 1H, 2T, 2B	1